



Quality tools for the electronics industry



HAKKO Glo



HAKKO brand is much loved in more than 50 countries worldwide.

HAKKO has grown into a global brand. Our soldering irons and related equipment are hard at work in more than 50 countries. We have local branches and sales representatives around the world, and continue to expand our global network.



<http://www.hakko.com/>

Global Network



As of May 2013

《《《 WORLDWIDE NETWORK 》》》

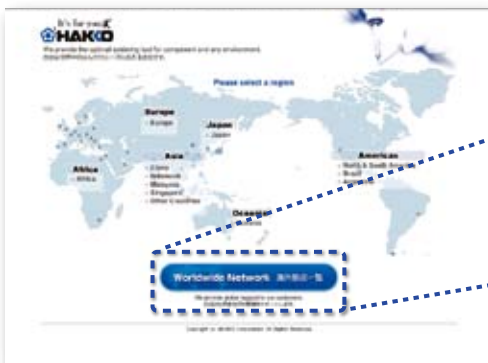

For more details on HAKKO affiliates and distributors, visit the official HAKKO website at www.hakko.com



Click!

Quality Tools for the



HAKKO is certified under ISO 9001 (JIS Q 9001),
 the international standard for quality management systems.
 We are also certified under ISO 14001 (JIS Q 14001)
 and are actively involved in preserving the global environment.

See the official HAKKO website for all necessary information
 regarding HAKKO products and services.

• HAKKO WEBSITE



• SELECT TIP SHAPE

Search for the appropriate tip for your work by following the guidelines.



http://www.hakko.com/english/tip_selection/

• DOCUMENT PORTAL

Download instruction manuals, MSDSs, and technical documents from the HAKKO Document Portal.

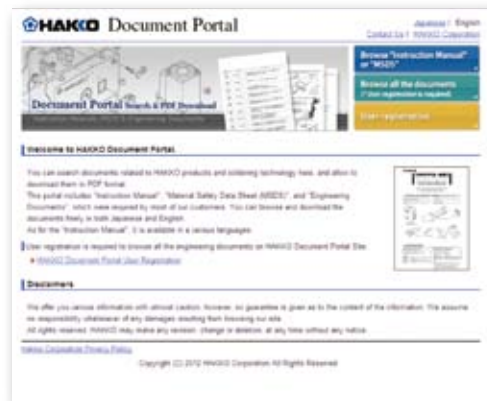

<https://doc.hakko.com/?l=en>

Electronics Industry

New
Products



HAKO FX-888D ESD SAFE
SOLDERING STATION

All-Round Soldering Station

Page
8

HAKO FX-600 · HAKO FX-601
SOLDERING IRON STAINED GLASS

Temperature Adjustable Soldering Iron

Page
30

FX-600
For electronics parts

FX-601
For heavy duty soldering



HAKO FM-206 ESD SAFE
REWORK SYSTEM

High Performance 3-Port Rework Station

Page
18



Index

Soldering Iron

All-round Soldering Station & Accessories

FX-888D
Soldering station (65W)



P.8

FX-8801
Soldering iron



P.8

FX-8803
Soldering gun



P.10

FX-8804
Hot tweezer



P.10

High Performance Soldering Station

FX-951
(70W)



P.12

FX-950
(70W)



P.12

FX-838
(150W)



P.16

High Performance Rework Station & Accessories

FM-203
2-port type



P.18

FM-206
3-port type

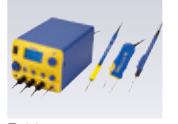

P.18

FM-207
Soldering iron (70W)



P.19

FM-2022
Hot tweezer



P.19

FM-2023
Mini hot tweezer



P.19

FM-2024
Desoldering iron



P.19

FM-2029
Hot air pencil



P.19

FM-2030
Soldering iron (150W)



P.19

N₂ System & Soldering Iron

FX-780
N₂ generator



P.26

FX-791
N₂ flow meter



P.26

FX-8802
(65W)



P.26

FM-2026
(70W)



P.26

FM-2031
(140W)



P.26

FX-8302
(150W)



P.26

Ceramic Heater Type

FX-600
For electronics parts soldering



P.30

FX-601
For heavy duty soldering

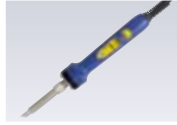

P.30

DASH

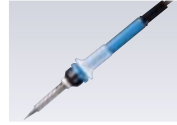

P.32

PRESTO



P.33

Battery-powered Type

FX-901



P.34

Nichrome Heater Type

RED



P.35

Built-in Solder Feed Type

MG



P.35

Soldering Pot

Soldering Pot

FX-301B
High performance type



P.36

FX-300
High performance type

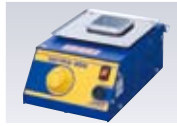

P.36

96/96-1



P.38

Flow Soldering System

485



P.38

Soldering Related Equipment and Materials

Tools for Lead and Wire

FT-801
Thermal wire stripper



P.39

153/154
Lead cutter and former



P.40

155
Lead cutter



P.40

152B
Motor drive



P.41

DIP LINER
Lead straightener

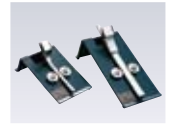

P.41

106
Cutting tool



P.47

Self Feeder

373
Self feeder



P.44

375
V-groove maker



P.46

Tip Cleaner / Polisher

FT-710
Tip cleaner



P.42

FT-700/FS-100
Tip polisher



P.43

Iron Holder & Reel Stand

Iron holder



P.47

611



P.47

Vacuum Pick-up Tool

392
Station type



P.48

393
Dropper type



P.48

394
Battery-powered type



P.48

Desoldering / Rework

Desoldering Tool

FM-204
Pump built-in type (70W)



P.50

474
Pump built-in type (50W)



P.52

475
External air compressor type (50W)



P.52

809
Gun type



P.52

815
Stick type (Lead-free)



P.52

816
Gun type (Lead-free)



P.52

484
Compact type



P.54

808
Portable type



P.54

SPPON

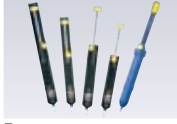

P.55

WICK



P.55

Rework System

701



P.56

702B



P.57

Preheater

FR-870
IR type



P.58

FR-830
Hot air type



P.59

SMD Rework Station & Accessories

FR-801
Analog type



P.60

FR-802
Digital type



P.60

FR-803B
BGA-SMD rework station



P.60

Nozzle tray



P.64

Fixture



P.64

Omnivise



P.64

851
For chip components



P.65

Smoke Absorber

Air Purifying Type

FA-430



P.66

Desktop Type

FA-400

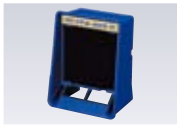

P.70

490



P.68

Line Production System

494



P.69

Static Control

Static Eliminator

FE-510



P.71

Wrist Strap

442B



P.72

496



P.72

Meter / Tester

Thermometer

FG-100



P.74

Soldering Tester

FG-101



P.74

Static Level Meter

FG-450



P.73

Wrist Strap Tester

498



P.76

Glue Gun / Heating Gun

Glue Gun

804













P.77



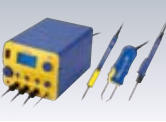



Heating Gun

880B/881/882

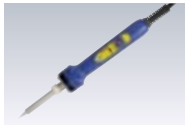

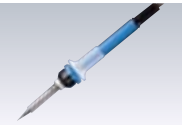
P.78

		FX-888D	FX-951	FX-950	FX-838	FM-203	FM-206	
								
Specifications	Power consumption of Handpiece	65 W	70 W	70 W	150 W	70 W × 2 port	70 W × 3 port	
	Temperature Range	200 to 480°C	200 to 450°C	200 to 450°C	200 to 500°C	200 to 450°C	200 to 450°C	
	Soldering Tip	T18 series	T12 series	T12 series	T20 series	T12 series	T12 series	
Applicable Standard	Lead Free Suggestible	●	●	●	●	●	●	
	ESD Safe	●	●	●	●	●	●	
	RoHS Suggestible	●	●	●	●	●	●	
Accessories	SMD Hot Tweezers connectable	●				●	●	
	N ₂ Soldering Iron connectable	●	●	●	●	●	●	
	Desoldering Iron connectable					●	●	
	Hot Air Handpiece connectable						●	
	Self Feeder connectable	●	●	●	●	●	●	
	Heavy Duty Soldering Iron connectable				● *Standard feature		●	
Function	Auto Shutoff Function: When a set time passed, the function stops to supply power to the heating element.							
			●		●	●	●	
	Auto Sleep Function: When a set time passed, the tip temperature decreases to a set lower temperature.							
			●	● *Option	●	●	●	
	Lock Function: Lockable by Password, Control card or Lock key.							
		Password	Control card	Lock key	Control card	Control card	Password	
	Lower Temperature Error Alert: When the temperature drops below a set limit, an error is displayed and the buzzer sounds.							
			●		●	●		
Offset Temperature Function: Temperature offsettable by Analog, Digital or Adjustment mode.								
	Adjustment mode	Digital	Manual	Digital	Digital	Digital		
Preset Temperature Function: The function allows to input several frequently-used temperatures and recall with one push of a button.								
	●			●		●		

FX-600	FX-601	DASH	PRESTO	FX-901	RED	MG
						
50 W	47 W	15 W/20 W/25 W	20 W/130 W	Allaline Batteries: 6 V (6 W)/ Nickel-Hydrogen Batteries (2150 mAh): 4.8 V (5 W)	20 W/30 W/ 40 W/60 W	30 W/40 W/60 W/ 80 W/100 W/150 W
200 to 500°C	240 to 540°C	—	—	—	—	—
T18 series	T19 series	N452-T series N453-T series	980-T series	T11 series	BB series	582-T-4 585-T-6 587-T-8 592-T-10
●	●					
●	●					
●	●	●	●	●	●	●
Lock key	Lock key					
Manual	Manual					

All-Round Soldering Station

HAJKO FX-888D

SOLDERING STATION

ESD
SAFE



All-Round Soldering Station **Digital**

Tip included



- Features Adjustment mode, Preset mode, and Password function
- Separable tip/heater design provides superior cost performance.

Packing List

FX-888D	Station, Handpiece (FX-8801), Iron holder, Instruction manual
---------	---

Specifications

Model No.	FX-888D
Power consumption	70 W
Temperature range	200 to 480°C
Temperature stability	±1°C at idle temperature

Station

Output voltage	AC 26 V
Dimensions	100 (W) × 120 (H) × 120 (D) mm
Weight	1.2 kg

Soldering Iron

Power consumption	65 W (26 V)
Tip to ground resistance	<2 Ω
Tip to ground potential	<2 mV
Heating element	Ceramic heater
Standard tip	Shape-B (No.T18-B)
Cord length	1.2 m
Total length*	217 mm (with B tip)
Weight*	46 g (with B tip)

* Without cord

Features

Strict temperature management

● Digital display

The FX-888D's digital display makes it easy to check the set temperature at a glance.

● Password function

Settings can be locked using a password to prevent them from being changed unexpectedly.

● Preset mode

Simply select the desired temperature from a selection of preset temperatures registered in advance. (Up to 5 preset temperatures can be registered.)



● Adjustment mode

With adjustment mode, what used to be a troublesome procedure is now as simple as entering the measured tip temperature in the FX-888D.



Measuring the tip temperature with a tip thermometer (HAKKO FG-100)

Graph of a comparison of the performance of the HAKKO FX-888D and a conventional station

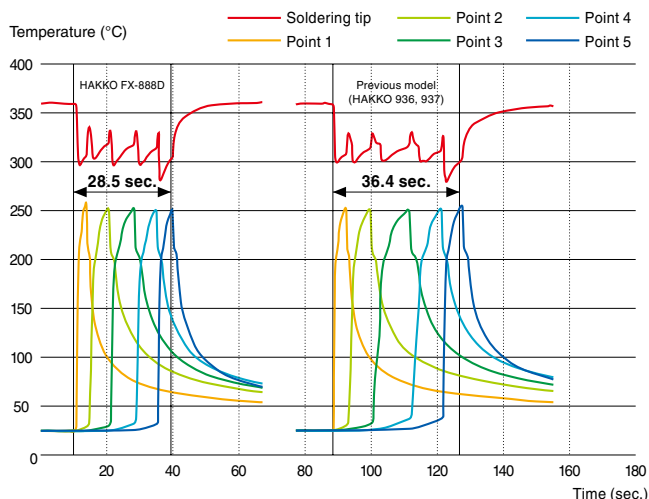

Test criteria

Measurement method	Thermocouples are mounted on the tip and the soldered portion on the board, and the time until the soldered portion reaches 250°C is measured for 5 points.
Board	Paper phenol copper board
Component used	Connector
Tip shape	Shape-1.2D
Temperature setting	360°C
Solder	Lead-free solder (Sn/Ag/Cu), diameter: 0.5 mm

HAKKO FX-8802 SOLDERING IRON ESD SAFE

N₂ Soldering Iron

Tip included



HAKKO FX-8803 SOLDERING GUN ESD SAFE

Soldering Gun

Tip included



HAKKO FX-8804 SMD HOT TWEEZER ESD SAFE

SMD Hot Tweezers

Tip included



Packing List

FX-8802	Handpiece, Shield plate, Instruction manual
FX-8803	Handpiece, Instruction manual
FX-8804	Handpiece, Caution label, Heat resistant pad, Instruction manual

NOTE: The soldering iron cannot be used as a standalone device.

Specifications

Model No.	FX-8802
Power consumption	65 W (26 V)
Temperature range	200 to 450°C
Tip to ground resistance	<2 Ω
Tip to ground potential	<2 mV
Heating element	Ceramic heater
Standard tip	Shape-B (No.T18-B)
Cord length	1.2 m
Total length*	190 mm (with B tip)
Weight*	59 g (with B tip and nozzle assembly A)

* Without cord and tube

Model No.	FX-8803
Power consumption	65 W (26 V)
Temperature range	200 to 480°C
Tip to ground resistance	<2 Ω
Tip to ground potential	<2 mV
Heating element	Ceramic heater
Standard tip	Shape-3C pre-tinned surface 45° (No.T18-CF3)
Guide nozzle	ø1.0 mm (All order sizes are optional.)
Usable solder diameter	0.6, 0.8, 1.0, 1.2, 1.6 mm
Cord length	1.1 m
Dimensions	170 (W) × 180 (H) × 23 (D) mm
Weight*	177 g

* Without cord

Model No.	FX-8804
Power consumption	65 W (26 V)
Temperature range	200 to 400°C
Tip to ground resistance	<2 Ω
Tip to ground potential	<2 mV
Heating element	Ceramic heater
Standard tip	Shape-2L (No. A1378) 2 pcs/set
Cord length	1.2 m
Total length*	186 mm
Weight*	93 g

* Without cord

Option

FX-8803

Part No.	Name	Specifications
C1437	Iron holder (with cleaning sponge)	-

FX-8804

Part No.	Name	Specifications
FH800-04BY	Iron holder (with cleaning sponge)	Blue & yellow
B3666	Holder clip	-

Replacement Tips for the FX-8801 and FX-8803

Unit: mm

<p>Applicable for FX-8803</p> <p>T18-B</p>	<p>Applicable for FX-8803</p> <p>T18-SB</p>	<p>T18-BR02</p>	<p>T18-BL</p>	<p>T18-C05</p>
<p>Applicable for FX-8803</p> <p>T18-C08</p>	<p>Applicable for FX-8803</p> <p>T18-C1 T18-CF1*</p>	<p>T18-CF15*</p>	<p>Applicable for FX-8803</p> <p>T18-C2 T18-CF2*</p>	<p>Applicable for FX-8803</p> <p>T18-CSF25*</p>
<p>Applicable for FX-8803</p> <p>T18-C3 T18-CF3*</p>	<p>Applicable for FX-8803</p> <p>T18-C4 T18-CF4*</p>	<p>T18-C5</p>	<p>Applicable for FX-8803</p> <p>T18-K</p>	<p>T18-D08</p>
<p>T18-D12</p>	<p>Applicable for FX-8803</p> <p>T18-D16</p>	<p>Applicable for FX-8803</p> <p>T18-D24</p>	<p>Applicable for FX-8803</p> <p>T18-D32</p>	<p>T18-DL12</p>
<p>T18-DL2</p>	<p>T18-DL32</p>	<p>T18-S3</p>	<p>Applicable for FX-8803</p> <p>T18-S4</p>	<p>T18-S6</p>
<p>T18-S9</p>	<p>T18-I</p>	<p>* These tips are tinned on the soldering surface only.</p>		

Replacement Tips and Nozzles for the FX-8802

Please see the replacement tips on P.29

Replacement Tips for the FX-8804

For Chip Component

Part No.	Name	Size of A (B)	Tip Shape
A1577	Tip/CHIP 0.5L	0.5 mm	
A1379	Tip/CHIP 1L	1 mm	
A1378	Tip/CHIP 2L	2 mm	
A1388	Tip/CHIP 0.5C	1.5 (0.5) mm	
A1389	Tip/CHIP 0.5I	R0.25 mm	
A1576	Tip/CHIP 2.6C	2.6 mm	

For SOP Component

Part No.	Name	Size of A	Tip Shape
A1390	Tip/SOP 4L	4 mm	
A1391	Tip/SOP 6L	6 mm	
A1380	Tip/SOP 8L	8 mm	
A1381	Tip/SOP 10L	10 mm	
A1382	Tip/SOP 13L	13 mm	
A1392	Tip/SOP 15L	15 mm	
A1383	Tip/SOP 18L	18 mm	
A1384	Tip/SOP 20L	20 mm	
A1385	Tip/SOP 25L	25 mm	

High Performance Soldering Station

HAKKO FX-951 SOLDERING STATION ESD SAFE

High Performance Soldering Station **Digital**

Tip not included

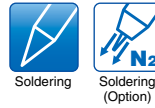

- Compact high-power thermally-controlled soldering iron
- Informs you of errors via a warning buzzer or display

HAKKO FX-950 SOLDERING STATION ESD SAFE

High Performance Soldering Station **Analog**

Tip not included

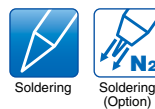

- Analog type high-power soldering iron
- “Lock key” can lock the temperature setting.
- Informs you of various errors via a lamp

Features

Thermal recovery graph (Comparison of HAKKO products)

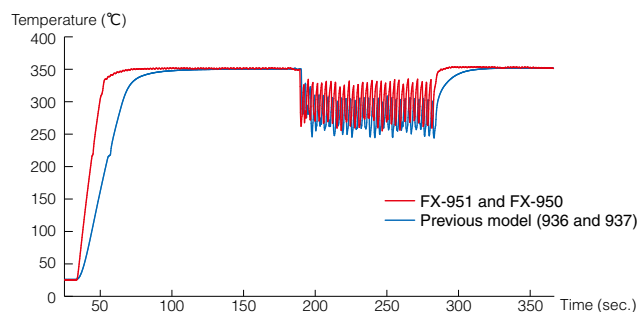

Test criteria

Measurement method	A thermocouple is mounted on the tip and the tip temperature is measured when soldering $\varnothing 1.6 \text{ mm} \times 5 \text{ mm}$ solder to paper phenol copper board once every 3 seconds.
Board	Paper phenol copper board.
Temperature setting	350°C
Solder	Lead-free solder (Sn/Ag/Cu), diameter: 1.6 mm x 5 mm

Composite tip

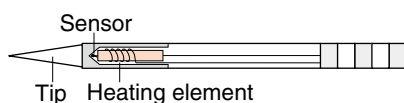

The composite tip with an integrated heating element and sensor offers superior thermal responsivity and thermal recovery.

85 Tip variations



Packing List

FX-951	Station, Handpiece (FM-2028), Control card, Power cord, Connection cable, Heat resistant pad, Iron holder, Instruction manual
FX-950	Station, Handpiece (FM-2028), Lock key, Heat resistant pad, Iron holder, Instruction manual

Specifications

Model No.	FX-951 and FX-950
Power consumption	75 W
Temperature range	200 to 450°C
Temperature stability	$\pm 5^\circ\text{C}$ at idle temperature

Station

Output voltage	AC 24 V
Dimensions	FX-951: 80 (W) x 130 (H) x 131 (D) mm FX-950: 80 (W) x 118 (H) x 138 (D) mm
Weight	1.2 kg

Soldering Iron

Power consumption	70 W (24 V)
Tip to ground resistance	$< 2 \Omega$
Tip to ground potential	$< 2 \text{ mV}$
Heating element	Composite heater
Cord length	1.2 m
Total length*	188 mm (with 2.4D tip)
Weight*	30 g (with 2.4D tip)

* Without cord

Option

Part No.	Name	Specifications
FH200-01	Iron holder	With power-save function and cleaning wire
FH200-02	Iron holder	With power-save function and cleaning sponge

* In order to use the power-save function with the FX-950, the FH200-01 or FH200-02 iron holder is required.

High Performance Soldering Station

Optional Tips for the FM-2028

Unit: mm

Standard type



B	T12-B Shape-B	T12-B2 Shape-0.5B	T12-B3 Shape-0.7B	T12-B4 Shape-0.4B	T12-BL Shape-BL
BC	T12-BC1 Shape-1BC	T12-BCF1* Shape-1BC	T12-BC2 Shape-2BC	T12-BCF2* Shape-2BC	T12-BC3 Shape-3BC
	T12-BCF3* Shape-3BC	T12-BCM2 Shape-2BC with Indent	T12-BCM3 Shape-3BC with Indent		
C	T12-C08 Shape-0.8C	T12-C1 Shape-1C	T12-C4 Shape-4C	T12-CF4* Shape-4C	
D	T12-D08 Shape-0.8D	T12-D12 Shape-1.2D	T12-D16 Shape-1.6D	T12-D24 Shape-2.4D	T12-D4 Shape-4D
	T12-D52 Shape-5.2D	T12-DL08 Shape-0.8DL	T12-DL12 Shape-1.2DL	T12-DL32 Shape-3.2DL	T12-DL52 Shape-5.2DL
I	T12-I Shape-I	T12-IL Shape-IL	T12-ILS Shape-ILS		
J	T12-J02 Shape-0.2J	T12-JL02 Shape-0.2JL	T12-JS02 Shape-0.2JS		
K	T12-K Shape-K	T12-KF Shape-KF	T12-KL Shape-KL	T12-KR Shape-KR	T12-KU Shape-KU

* These tips are tinned on the soldering surface only.

SMD type

Quad	T12-1201 Quad 13.6 x 8.5 	T12-1202 Quad 10.3 x 10.3 	T12-1203 Quad 12.8 x 12.8 	T12-1204 Quad 17.9 x 17.9 	T12-1205 Quad 23.4 x 17.3
	T12-1206 Quad 22.5 x 16.5 	T12-1207 Quad 15.5 x 15.5 	T12-1208 Quad 15.8 x 15.8 	T12-1209 Quad 8.4 x 8.4 	
Tunnel	T12-1001 Tunnel 5.1 x 4.6 	T12-1002 Tunnel 5.1 x 10.4 	T12-1003 Tunnel 9.5 x 18.3 	T12-1004 Tunnel 9.5 x 15.8 	T12-1005 Tunnel 9.5 x 13.2
	T12-1006 Tunnel 6.9 x 11.4 	T12-1007 Tunnel 7.9 x 18.8 	T12-1008 Tunnel 19.5 x 10.2 	T12-1009 Tunnel 13.4 x 20.5 	T12-1010 Tunnel 19.5 x 12
Spatula	T12-1401 Spatula 10.4 	T12-1402 Spatula 15.7 	T12-1403 Spatula 21.2 	T12-1404 Spatula 25 	T12-1405 Spatula 32
	T12-1406 Spatula 40 				

Long life type

T12-B2Z Shape-0.5B (Z) 	T12-BC1Z Shape-1BC (Z) 	T12-BCF1Z* Shape-1BC (Z) 	T12-BC2Z Shape-2BC (Z) 	T12-BCF2Z* Shape-2BC (Z) 	T12-BC3Z Shape-3BC (Z)
T12-BCF3Z* Shape-3BC (Z) 	T12-BZ Shape-B (Z) 	T12-C4Z Shape-4C (Z) 	T12-CF4Z* Shape-4C (Z) 	T12-D12Z Shape-1.2D (Z) 	T12-D16Z Shape-1.6D (Z)
T12-D24Z Shape-2.4D (Z) 	T12-D4Z Shape-4D (Z) 	T12-KFZ Shape-KF (Z) 	T12-KRZ Shape-KR (Z) 		

* These tips are tinned on the soldering surface only.

Heavy duty type

T12-WB2 Shape-0.5WB 	T12-WD08 Shape-0.8WD 	T12-WD12 Shape-1.2WD 	T12-WD16 Shape-1.6WD 	T12-WD52 Shape-5.2WD 	T12-WI Shape-WI

Heavy Duty Soldering Iron

HAKO FX-838 SOLDERING STATION ESD SAFE

Heavy Duty Soldering Iron Digital

Tip not included

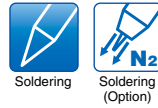

- High powered 150 W soldering iron
- Best suited for soldering of power-supply boards, heat sinks, and shield cases
- Applicable also to the soldering of multilayer boards with micro components

Optional Tips for the FX-8301

Unit: mm

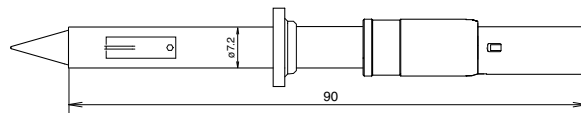

T20-B2 Shape-0.5B 	T20-BC2 Shape-2BC 	T20-BC3 Shape-3BC 	T20-BC4 Shape-4BC 	T20-BCF2* Shape-2BC
T20-BCF3* Shape-3BC 	T20-BCF4* Shape-4BC 	T20-BCM2 Shape-2BC with Indent 	T20-BCM3 Shape-3BC with Indent 	T20-BL Shape-BL
T20-BL2 Shape-2BL 	T20-BL3 Shape-3BL 	T20-C5 Shape-5C 	T20-C6 Shape-6C 	T20-D16 Shape-1.6D
T20-D24 Shape-2.4D 	T20-D32 Shape-3.2D 	T20-D6 Shape-6D 	T20-J02 Shape-0.2J (0.2RSB) 	T20-K Shape-K
T20-KU Shape-KU 	<p>* These tips are tinned on the soldering surface only.</p>			

Features

Graph of a comparison of the performance of the HAKKO FX-838 and a conventional station

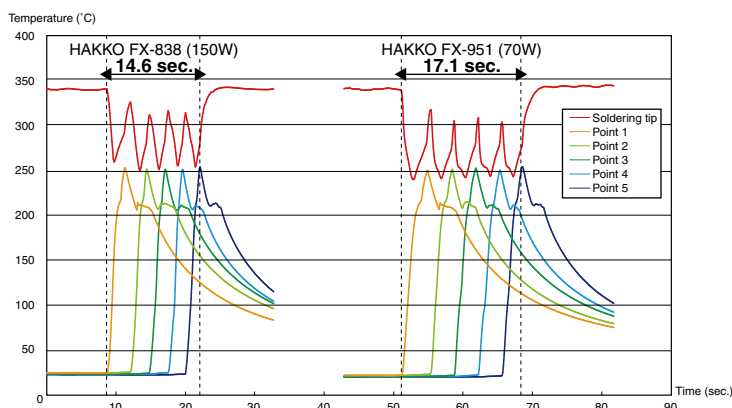

Test criteria

Measurement method	Thermocouples are mounted on the tip and the soldered portion on the board, and the time until the soldered portion reaches 250°C is measured for 5 points.
Board	Bakelite board
Component used	Terminal
Tip shape	Shape-1.6D
Temperature setting	340°C
Solder	Lead-free solder (Sn/Ag/Cu), diameter: 0.5 mm

Temperature preset mode

The temperature preset mode allows you to input three frequently-used temperatures in advance and recall them with one push of a button.

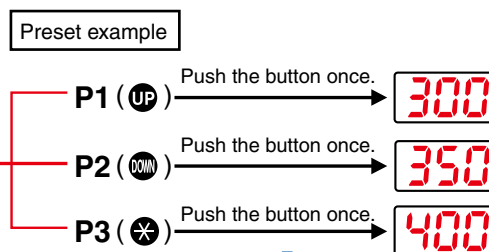

One push of a button can quickly recall each setting.

Connectable with N₂ soldering iron

To improve solder wettability and spreadability

HAKKO FX-8302 ESD SAFE SOLDERING IRON

N₂ Soldering Iron

Tip not included



For further details, see the N₂ soldering system (P.26).

Packing List

FX-838	Station, Handpiece (FX-8301), Control card, Power cord, Heat resistant pad, Connecting cable, Iron holder, Instruction manual
FX-8302	Handpiece, Instruction manual

Specifications

Model No.	FX-838
Power consumption	158 W
Temperature range	200 to 500°C
Temperature stability	±5°C at idle temperature

Station

Output voltage	AC 27 V
Dimensions	110 (W) × 110 (H) × 205 (D) mm
Weight	3.2 kg

Soldering Iron

Power consumption	150 W (27 V)
Tip to ground resistance	<2 Ω
Tip to ground potential	<2 mV
Heating element	Ceramic heater
Cord length	1.2 m
Total length*	175 mm (with 2.4D tip)
Weight*	31 g (with 2.4D tip)

* Without cord

Model No.	FX-8302
Power consumption	150 W (27 V)
Temperature range	200 to 500°C
Tip to ground resistance	<2 Ω
Tip to ground potential	<2 mV
Heating element	Ceramic heater
Cord length	1.2 m
Total length	195 mm (with 2.4D tip)
Weight	41 g (with 2.4D tip and nozzle assembly D)

* Without cord and tube

High Performance Rework Station & Accessories

HAJKO FM-203 SOLDERING STATION ESD SAFE

2-Port High Performance Rework Station

Digital

Tip not included

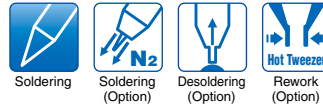

- 2 handpieces can be connected at the same time.

HAJKO FM-206 REWORK SYSTEM ESD SAFE

3-Port High Performance Rework Station

Digital

Tip not included

Nozzle not included



- 3-port rework station that enables soldering, desoldering, and SMD rework all with a single unit
- Graphic LCD enables easy viewing and operation.

Handpiece Combination Examples

FM-203



Handpiece	Channel D connector	Channel S connector
FM-2027	○	○
FM-2022 *1	○	×
FM-2023 *1	○	×
FM-2024 *2	○	○
FM-2026 *3	○	○

*1 When the FM-2022 or FM-2023 is connected to the channel D connector, both channel connectors can't be used at the same time.

*2 When two FM-2024s are connected to the channel connectors, each FM-2024 must be connected to the desolder control box.

*3 For the FM-2026, each handpiece needs an N₂ generator (HAKKO FX-780), flow meter (HAKKO FX-791), compressor, regulator, etc. For further details, see the N₂ soldering system (P.26).

FM-206

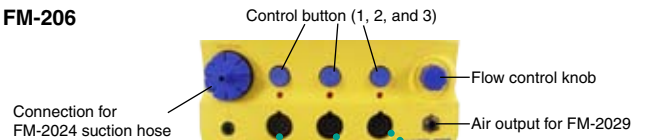

Handpiece	Receptacle 1	Receptacle 2	Receptacle 3
FM-2027	○	○	○
FM-2024	○ *1	○	○ *1
FM-2029	×	×	○
FM-2022	×	○	×
FM-2023	×	○	×
FM-2026	○	○	○
FM-2030	×	○	○
FM-2031	×	○ *2	○ *2

*1 The FM-2024 can be connected to receptacle 2 and 3. However, only one FM-2024 can be used with the station.

*2 For the FM-2031 and FM-2026, each handpiece needs an N₂ generator (HAKKO FX-780), flow meter (HAKKO FX-791), compressor, regulator, etc. For further details, see the N₂ soldering system (P.26).

NOTE: The FM-2024 and FM-2029 can't be used at the same time.

Accessories

HAJKO SOLDERING IRON **FM-2027** ESD SAFE

Soldering Iron

Tip not included



HAJKO SOLDERING IRON **FM-2026** ESD SAFE

70 W N₂ Soldering Iron

Tip not included



HAJKO MODEL **FM-2022** ESD SAFE
PARALLEL REMOVER

SMD Hot Tweezers

Tip not included



HAJKO HOT AIR HANDPIECE **FM-2029** ESD SAFE

Hot-Air Pencil

Nozzle not included



HAJKO MODEL **FM-2023** ESD SAFE
MINI PARALLEL REMOVER

Mini SMD Hot Tweezers

Tip included



HAJKO SOLDERING IRON **FM-2030** ESD SAFE

Heavy Duty Soldering Iron

Tip not included



HAJKO MODEL **FM-2024** ESD SAFE
DESOLDERING TOOL

Desoldering Tool

Nozzle not included



HAJKO SOLDERING IRON **FM-2031** ESD SAFE

140 W N₂ Soldering Iron

Tip not included



High Performance Rework Station & Accessories

Specifications

Model No.	FM-203
Power consumption	140 W
Temperature range	200 to 450°C
Temperature stability	±5°C at idle temperature

Station

Output voltage	AC 24 V
Dimensions	120 (W) × 120 (H) × 190 (D) mm
Weight	2.7 kg

Soldering Iron (FM-2027)

Power consumption	70 W (24 V)
Tip to ground resistance	<2 Ω
Tip to ground potential	<2 mV
Heating element	Composite heater
Cord length	1.2 m
Total length*	188 mm (with 2.4D tip)
Weight*	30 g (with 2.4D tip)

* Without cord

Model No.	FM-206
Power consumption	410 W (max.)
Temperature range	FM-2026/2027: 200 to 450°C FM-2022/2023: 200 to 400°C FM-2024: 350 to 450°C FM-2029: 100 to 550°C FM-2030: 200 to 500°C FM-2031: 200 to 500°C
Temperature stability	±5°C at idle temperature

Station

Output voltage	AC 24 V
Vacuum generator	Cylinder type vacuum pump
Vacuum pressure	80 kPa (600 mmHg, max.)
Suction flow	14 L/min.
Air flow	6 L/min. (max.)
Dimensions	162 (W) × 136 (H) × 245 (D) mm
Weight*	6.2 kg

Soldering Iron (FM-2027)

Power consumption	70 W (24 V)
Tip to ground resistance	<2 Ω
Tip to ground potential	<2 mV
Heating element	Composite heater
Cord length	1.2 m
Total length*	188 mm (with 2.4D tip)
Weight*	30 g (with 2.4D tip)

Desoldering Tool (FM-2024)

Power consumption	70 W (24 V)
Nozzle to ground resistance	<2 Ω
Nozzle to ground potential	<2 mV
Heating element	Composite heater
Cord length	1.2 m
Total length*	180 mm (with ø1.0 mm nozzle)
Weight**	65 g (with ø1.0 mm nozzle)

Hot Air Handpiece (FM-2029)

Power consumption	140 W (24 V)
Nozzle to ground resistance	<2 Ω
Nozzle to ground potential	<2 mV
Heating element	Composite heater
Cord length	1.2 m
Total length**	232 mm (with ø4.0 mm nozzle)
Weight***	50 g (with ø4.0 mm nozzle)

* Without cord

** Without cord and hose

*** Without cord and tube

Model No.	FM-2022
Power consumption	140 W (24 V)
Tip to ground resistance	<2 Ω
Tip to ground potential	<2 mV
Heating element	Composite heater
Cord length	1.2 m
Total length*	148 mm (with SOP 25L tip)
Weight*	64 g (with SOP 25L tip)

* Without cord

Model No.	FM-2023
Power consumption	140 W (24 V)
Tip to ground resistance	<2 Ω
Tip to ground potential	<2 mV
Heating element	Composite heater
Standard tip	Shape-I: 2 pcs/set (No.T9-I)
Cord length	1.2 m
Total length*	117 mm (with I tip)
Weight*	37 g (with I tip)

* Without cord

Model No.	FM-2024
• Desoldering Tool	
Power consumption	70 W (24 V)
Nozzle to ground resistance	<2 Ω
Nozzle to ground potential	<2 mV
Heating element	Composite heater
Cord length	1.2 m
Total length*	180 mm (with ø1.0 mm nozzle)
Weight*	65 g (with ø1.0 mm nozzle)

• Desolder Control Box

Power consumption	12 W (24 V)
Output voltage	24 V
Vacuum generator	Ejector type
Vacuum pressure	Max. 93 kPa (700 mmHg)
Suction flow	28 L/min.
Nozzle to ground potential	<2 mV
Applied air pressure	490 kPa (5.0 kgf/cm ²) While trigger or button is pressed
Compressed air consumption	46 L /min.
Outer dimensions	119 (W) × 45 (H) × 172 (D)mm
Weight*	1.2 kg

* Without cord

Model No.	FM-2026
Power consumption	70 W (24 V)
Tip to ground resistance	<2 Ω
Tip to ground potential	<2 mV
Heating element	Composite heater
Cord length	1.2 m
Total length	205 mm (with 2.4D tip)
Weight	45 g (with 2.4D tip and nozzle assembly C)

* Without cord and tube

Model No.	FM-2027
Power consumption	70 W (24 V)
Tip to ground resistance	<2 Ω
Tip to ground potential	<2 mV
Heating element	Composite heater
Cord length	1.2 m
Total length*	188 mm (with 2.4D tip)
Weight*	30 g (with 2.4D tip)

Specifications

Model No.	FM-2030
Power consumption	140 W (24 V)
Tip to ground resistance	<2 Ω
Tip to ground potential	<2 mV
Heating element	Composite heater
Cord length	1.3 m
Total length*	224 mm (with 2.4D tip)
Weight*	41 g (with 2.4D tip)

* Without cord

Model No.	FM-2031
Power consumption	140 W (24 V)
Tip to ground resistance	<2 Ω
Tip to ground potential	<2 mV
Heating element	Composite heater
Cord length	1.2 m
Total length	231 mm (with 2.4D tip)
Weight	47 g (with 2.4D tip and nozzle assembly E)

* Without cord and tube

Packing List

FM-203	Station, Handpiece (FM-2027), Sleeve assembly, Connecting cable, Power cord, Control card, Iron holder, Tip tray, Heat resistant pad, Instruction manual
FM-206	Station, Power cord, Tip tray, Desoldering tool (FM-2024), Handle (for gun configuration for FM-2024), Iron holder (for FM-2024), Ceramic paper filter (10 pcs; for FM-2024), Nozzle remover (for FM-2024), Cleaning drill for heating element (for FM-2024), Connecting cable (for FM-2024), Handpiece (FM-2027), Iron holder (for FM-2027), Heat resistant pad (for FM-2027), Connecting cable (for FM-2027), Hot air handpiece (FM-2029), Iron holder (for FM-2029), Heat resistant pad (for FM-2029), Connecting cable (for FM-2029), Instruction manual

FM-2022 (Conversion kit)	Parallel remover, Heat resistant pad, Iron holder, Connecting cable, Instruction manual
FM-2023 (Conversion kit)	Mini parallel remover, Soldering tip (T9-I), Heat resistant pad, Iron holder, Component bed, Connecting cable, Instruction manual
FM-2024 (Conversion kit, with DCB)	Desoldering tool, Handle (for gun configuration), Desoldering control box, Filter pipe assembly, Iron holder, Cleaning drill for heating element, Nozzle remover, Ceramic paper filter (10 pcs), Connecting cable, Instruction manual
FM-2026 (Conversion kit)	Handpiece, Sleeve cover, Sleeve assembly (yellow), Heat resistant pad, Iron holder, Connecting cable, Instruction manual
FM-2027 (Conversion kit)	Handpiece, Sleeve assembly (yellow), Heat resistant pad, Iron holder, Connecting cable
FM-2029 (Conversion kit)	Handpiece (hot air), Handpiece holder, Heat resistant pad, Connecting cable, Instruction manual
FM-2030 (Conversion kit)	Handpiece (soldering), Heat resistant pad, Iron holder, Connecting cable, Instruction manual
FM-2031 (Conversion kit)	Handpiece (soldering), Heat resistance pad, Iron holder, Connecting cable, Instruction manual

FM-2024 Features

Please see the features on P.51.

FM-2029 Features

Securely and easily remove 10 x 10 (mm) chips.



Turn on and off with a hand switch.



FM-2030 Features

Graph of a comparison of the performance of FM-2027 (70 W) and FM-2030 (140 W)

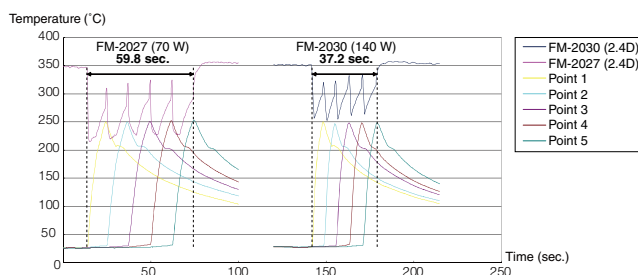

Test criteria

Test method	Solder at 5 points and measure the time until the temperature of the workpiece reaches 250°C.
Board	Bakelite board
Component used	Screw
Tip shape	Shape-2.4D
Temperature setting	350°C
Solder	Lead-free solder (Sn/Ag/Cu), diameter: 1.0 mm

High Performance Soldering Accessories

Optional Tips for the FM-2027

Unit: mm

Standard type

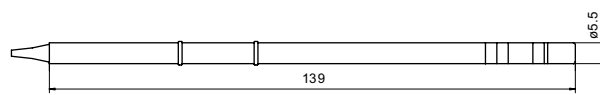

B	T12-B Shape-B	T12-B2 Shape-0.5B	T12-B3 Shape-0.7B	T12-B4 Shape-0.4B	T12-BL Shape-BL
BC	T12-BC1 Shape-1BC	T12-BCF1* Shape-1BC	T12-BC2 Shape-2BC	T12-BCF2* Shape-2BC	T12-BC3 Shape-3BC
	T12-BCF3* Shape-3BC	T12-BCM2 Shape-2BC with Indent	T12-BCM3 Shape-3BC with Indent		
C	T12-C08 Shape-0.8C	T12-C1 Shape-1C	T12-C4 Shape-4C	T12-CF4* Shape-4C	
D	T12-D08 Shape-0.8D	T12-D12 Shape-1.2D	T12-D16 Shape-1.6D	T12-D24 Shape-2.4D	T12-D4 Shape-4D
	T12-D52 Shape-5.2D	T12-DL08 Shape-0.8DL	T12-DL12 Shape-1.2DL	T12-DL32 Shape-3.2DL	T12-DL52 Shape-5.2DL
I	T12-I Shape-I	T12-IL Shape-IL	T12-ILS Shape-ILS		
J	T12-J02 Shape-0.2J	T12-JL02 Shape-0.2JL	T12-JS02 Shape-0.2JS		
K	T12-K Shape-K	T12-KF Shape-KF	T12-KL Shape-KL	T12-KR Shape-KR	T12-KU Shape-KU

* These tips are tinned on the soldering surface only.

SMD type

Quad	T12-1201 Quad 13.6 x 8.5 	T12-1202 Quad 10.3 x 10.3 	T12-1203 Quad 12.8 x 12.8 	T12-1204 Quad 17.9 x 17.9 	T12-1205 Quad 23.4 x 17.3
	T12-1206 Quad 22.5 x 16.5 	T12-1207 Quad 15.5 x 15.5 	T12-1208 Quad 15.8 x 15.8 	T12-1209 Quad 8.4 x 8.4 	
Tunnel	T12-1001 Tunnel 5.1 x 4.6 	T12-1002 Tunnel 5.1 x 10.4 	T12-1003 Tunnel 9.5 x 18.3 	T12-1004 Tunnel 9.5 x 15.8 	T12-1005 Tunnel 9.5 x 13.2
	T12-1006 Tunnel 6.9 x 11.4 	T12-1007 Tunnel 7.9 x 18.8 	T12-1008 Tunnel 19.5 x 10.2 	T12-1009 Tunnel 13.4 x 20.5 	T12-1010 Tunnel 19.5 x 12
Spatula	T12-1401 Spatula 10.4 	T12-1402 Spatula 15.7 	T12-1403 Spatula 21.2 	T12-1404 Spatula 25 	T12-1405 Spatula 32
	T12-1406 Spatula 40 				

Long life type

T12-B2Z Shape-0.5B (Z) 	T12-BC1Z Shape-1BC (Z) 	T12-BCF1Z* Shape-1BC (Z) 	T12-BC2Z Shape-2BC (Z) 	T12-BCF2Z* Shape-2BC (Z) 	T12-BC3Z Shape-3BC (Z)
T12-BCF3Z* Shape-3BC (Z) 	T12-BZ Shape-B (Z) 	T12-C4Z Shape-4C (Z) 	T12-CF4Z* Shape-4C (Z) 	T12-D12Z Shape-1.2D (Z) 	T12-D16Z Shape-1.6D (Z)
T12-D24Z Shape-2.4D (Z) 	T12-D4Z Shape-4D (Z) 	T12-KFZ Shape-KF (Z) 	T12-KRZ Shape-KR (Z) 		

* These tips are tinned on the soldering surface only.

Heavy duty type

T12-WB2 Shape-0.5WB 	T12-WD08 Shape-0.8WD 	T12-WD12 Shape-1.2WD 	T12-WD16 Shape-1.6WD 	T12-WD52 Shape-5.2WD 	T12-WI Shape-WI

High Performance Rework Station & Accessories

Optional Tips for the FM-2022

Unit: mm

CHIP

*1 set: 2 pcs

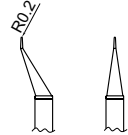
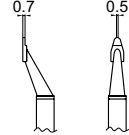
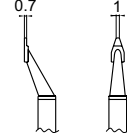
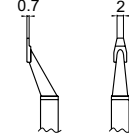
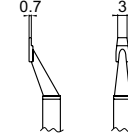
T8-1001 Chip 0.5L 	T8-1002 Chip 0.5C 	T8-1003 Chip 1L 	T8-1004 Chip 2L 	T8-1013 Chip 3L 
---	---	---	--	---

SOP

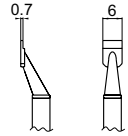
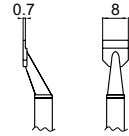
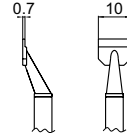
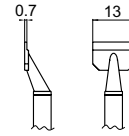
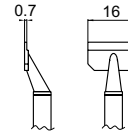
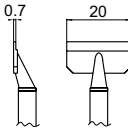
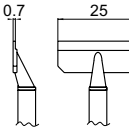
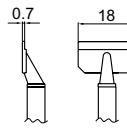
T8-1005 SOP 6L 	T8-1006 SOP 8L 	T8-1007 SOP 10L 	T8-1008 SOP 13L 	T8-1009 SOP 16L 
T8-1010 SOP 20L 	T8-1011 SOP 25L 	T8-1012 SOP 18L 		

Replacement Tips for the FM-2023

Unit: mm

CHIP

*1 set: 2 pcs

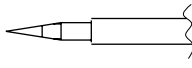
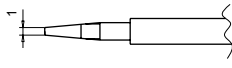
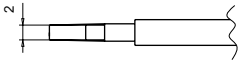
T9-I Chip I 	T9-L1 Chip 1L 	T9-L2 Chip 2L 
---	---	---

Optional Tips for the FM-2030

Unit: mm

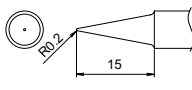
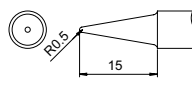
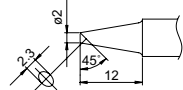
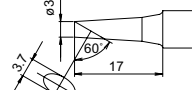
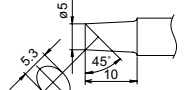
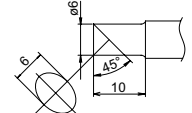
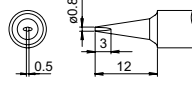
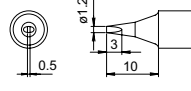
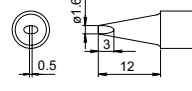
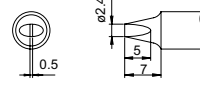
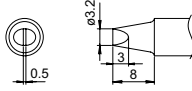
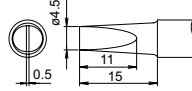
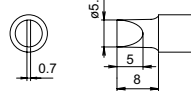
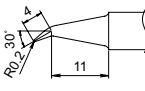
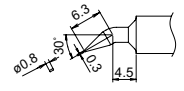
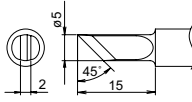
T22-BL Shape-BL 	T22-BL2 Shape-2BL 	T22-BC2 Shape-2BC 	T22-C3 Shape-3C 	T22-C5 Shape-5C 
T22-C6 Shape-6C 	T22-D08 Shape-0.8D 	T22-D12 Shape-1.2D 	T22-D16 Shape-1.6D 	T22-D24 Shape-2.4D 
T22-D32 Shape-3.2D 	T22-D45 Shape-4.5D 	T22-D52 Shape-5.2D 	T22-J02 Shape-0.2J 	T22-JD08 Shape-0.8JD 
T22-K Shape-K 				

Optional Nozzles for the FM-2024

Unit: mm

<p>N1-06 Nozzle $\phi 0.6$</p>	<p>N1-08 Nozzle $\phi 0.8$</p>	<p>N1-10 Nozzle $\phi 1.0$</p>	<p>N1-13 Nozzle $\phi 1.3$</p>	<p>N1-16 Nozzle $\phi 1.6$</p>
<p>N1-20 Nozzle $\phi 2.0$</p>	<p>N1-23 Nozzle $\phi 2.3$</p>	<p>N1-L10 Nozzle $\phi 1.0$ Long</p>		

Optional Nozzles for the FM-2029

Unit: mm

		ϕA	ϕB
N4-01 Nozzle $\phi 2.0$		2.0	2.5
N4-02 Nozzle $\phi 4.0$		4.0	5.0
N4-03 Nozzle $\phi 6.0$		6.0	7.0
N4-04 Nozzle $\phi 8.0$		8.0	9.0

Optional Tips for the FM-2026

Please see the optional tips on P.28.

Optional Tips for the FM-2031

Please see the optional tips on P.28.

N₂ System



- A preheating effect is achieved by passing nitrogen gas along the heating element in the handpiece.
- Improved wettability and spreadability
- Prevents oxidation

HAKKOFX-780

N. GENERATOR

N₂ Gas Generator



- Highest concentration of nitrogen gas: 99.9%
- Compact design reduces footprint.

HAKKOFX-791

N. STATION

N₂ Flowmeter



- Flowmeter for N₂ soldering iron with flow control valve and regulator

HAKKOFX-8802

SOLDERING IRON

ESD SAFE

65 W N₂ Soldering Iron

Tip included



HAKKOFM-2026

SOLDERING IRON

ESD SAFE

70 W N₂ Soldering Iron

Tip not included



HAKKOFM-2031

SOLDERING IRON

ESD SAFE

140 W N₂ Soldering Iron

Tip not included



HAKKOFX-8302

SOLDERING IRON

ESD SAFE

150 W N₂ Soldering Iron

Tip not included



Specifications

Model No.	FX-780
Air supply pressure	0.3 to 0.7 MPa
Concentration of generated N ₂	99.9% (max.)
Amount of generated N ₂	1.5 L/min. (When compressed air of 0.5 MPa is supplied at 25°C, the concentration of the generated nitrogen is 98%.)
Dimensions*	73 (W) × 282 (H) × 71 (L) mm
Weight**	1.5 kg

* Without sockets and valve
** Without racks

Model No.	FX-791
Pressure of discharged gas	0.2 MPa (2.0 kgf/cm ²)
Gas flow	0.25 to 2.5 L/min.
Dimensions	70 (W) × 121 (H) × 134 (D) mm
Weight	600 g

Packing List

FX-780	Unit, Rack for unit (2 pcs), Instruction manual
--------	---

FX-791	Unit, Instruction manual
--------	--------------------------

Improved solderability

- Wettability and spreadability comparisons

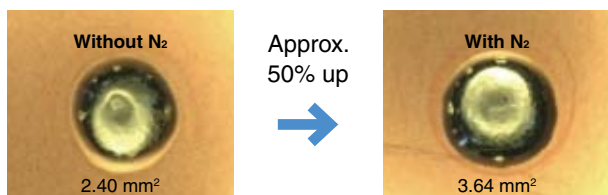

- Less bridging occurs even for components susceptible to bridging.

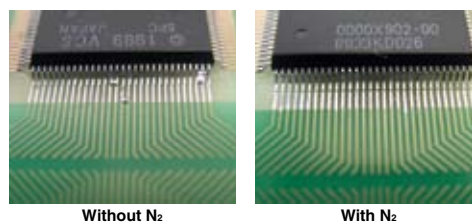

Connection Method

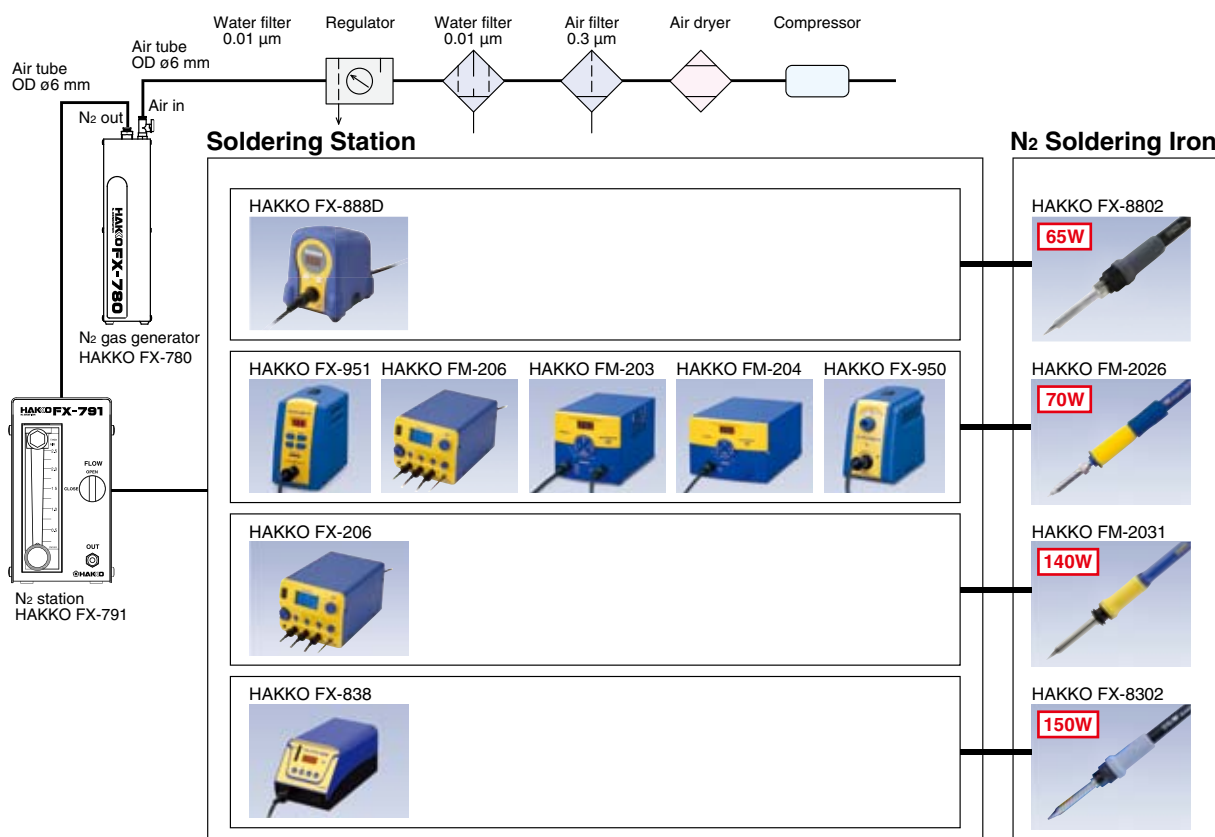

* Select one.

* Select one.





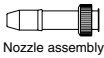
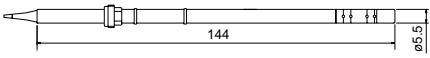
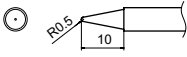
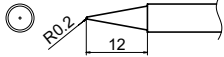
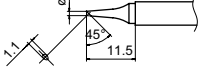
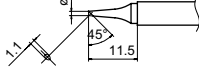
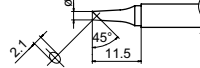
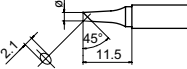
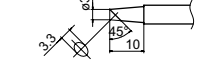
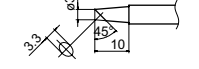
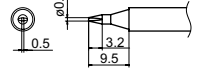
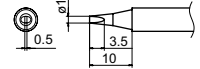
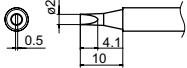
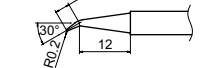
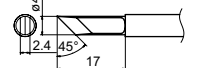
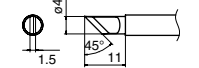
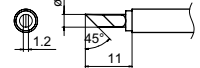
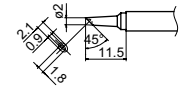
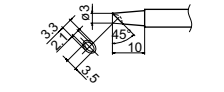

Optional Tips and Nozzles for the FM-2026

Unit: mm

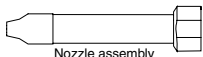
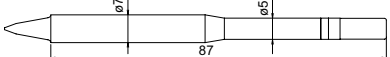
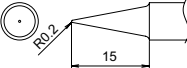
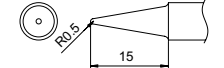
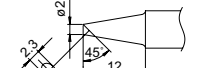
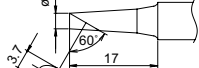
 				
T13-B2 Shape-0.5B 	T13-BL Shape-BL 	T13-BC1 Shape-1BC 	T13-BCF1* Shape-1BC 	T13-BC2 Shape-2BC 
B2708 Nozzle assembly C	B2898 Nozzle assembly E	B2899 Nozzle assembly F	B2899 Nozzle assembly F	B2706 Nozzle assembly A
T13-BCF2* Shape-2BC 	T13-BC3 Shape-3BC 	T13-BCF3* Shape-3BC 	T13-D08 Shape-0.8D 	T13-D16 Shape-1.6D 
B2706 Nozzle assembly A	B2900 Nozzle assembly G	B2900 Nozzle assembly G	B2709 Nozzle assembly D	B2708 Nozzle assembly C
T13-D24 Shape-2.4D 	T13-J02 Shape-0.2J 	T13-KF Shape-KF 	T13-KR Shape-KR 	T13-KU Shape-KU 
B2708 Nozzle assembly C	B2707 Nozzle assembly B	B2923 Nozzle assembly J	B2902 Nozzle assembly I	B2901 Nozzle assembly H
T13-BCM2 Shape-2BC with Indent 	T13-BCM3 Shape-3BC with Indent 			
B2706 Nozzle assembly A	B2900 Nozzle assembly G	* These tips are tinned on the soldering surface only.		

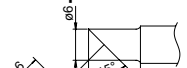
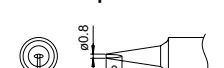

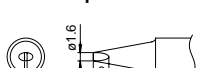
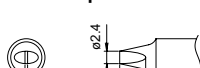
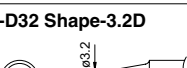
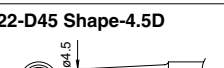
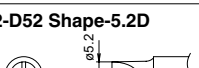
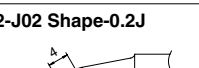
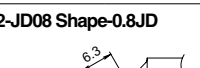



Optional Tips and Nozzles for the FM-2031

Unit: mm

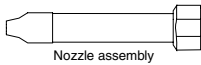
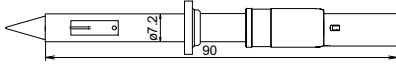
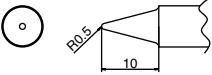
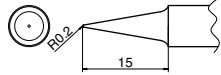
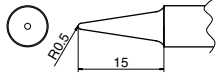
 				
T22-BL Shape-BL 	T22-BL2 Shape-2BL 	T22-BC2 Shape-2BC 	T22-C3 Shape-3C 	T22-C5 Shape-5C 
B3121 Nozzle assembly A	B3121 Nozzle assembly A	B3121 Nozzle assembly A	B3121 Nozzle assembly A	B3124 Nozzle assembly D
T22-C6 Shape-6C 	T22-D08 Shape-0.8D 	T22-D12 Shape-1.2D 	T22-D16 Shape-1.6D 	T22-D24 Shape-2.4D 
B3124 Nozzle assembly D	B3123 Nozzle assembly C	B3121 Nozzle assembly A	B3123 Nozzle assembly C	B3561 Nozzle assembly E
T22-D32 Shape-3.2D 	T22-D45 Shape-4.5D 	T22-D52 Shape-5.2D 	T22-J02 Shape-0.2J 	T22-JD08 Shape-0.8JD 
B3124 Nozzle assembly D	B3124 Nozzle assembly D	B3124 Nozzle assembly D	B3121 Nozzle assembly A	B3561 Nozzle assembly E
T22-K Shape-K 				
B3123 Nozzle assembly C				

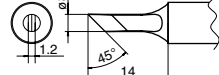
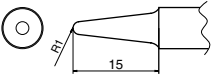
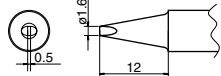
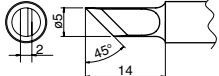

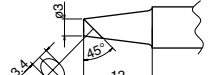
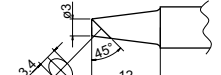
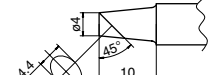
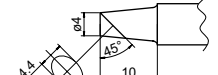
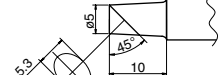
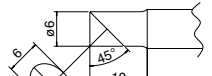

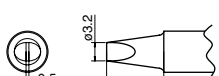
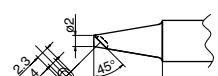
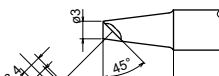
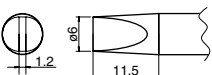
Optional Tips and Nozzles for the FX-8302

Unit: mm

 				
 T20-B2 Shape-0.5B	 T20-BL Shape-BL	 T20-BL2 Shape-2BL	 T20-J02 Shape-0.2J (0.2RSB)	 T20-KU Shape-KU
B3121 Nozzle assembly A	B3121 Nozzle assembly A	B3121 Nozzle assembly A	B3122 Nozzle assembly B	B3122 Nozzle assembly B
 T20-BL3 Shape-3BL	 T20-D16 Shape-1.6D	 T20-K Shape-K	 T20-BC2 Shape-2BC	 T20-BCF2* Shape-2BC
B3123 Nozzle assembly C	B3123 Nozzle assembly C	B3123 Nozzle assembly C	B3124 Nozzle assembly D	B3124 Nozzle assembly D
 T20-BC3 Shape-3BC	 T20-BCF3* Shape-3BC	 T20-BC4 Shape-4BC	 T20-BCF4* Shape-4BC	 T20-C5 Shape-5C
B3124 Nozzle assembly D	B3124 Nozzle assembly D	B3124 Nozzle assembly D	B3124 Nozzle assembly D	B3124 Nozzle assembly D
 T20-C6 Shape-6C	 T20-D24 Shape-2.4D	 T20-D32 Shape-3.2D	 T20-BCM2 Shape-2BC with Indent	 T20-BCM3 Shape-3BC with Indent
B3124 Nozzle assembly D	B3124 Nozzle assembly D	B3124 Nozzle assembly D	B3124 Nozzle assembly D	B3124 Nozzle assembly D
 T20-D6 Shape-6D				
B3561 Nozzle assembly E	* These tips are tinned on the soldering surface only.			

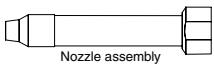
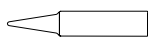
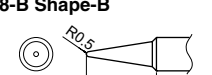
Replacement Tips and Nozzles for the FX-8802

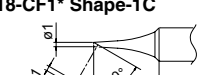
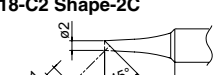
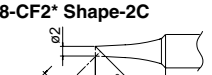
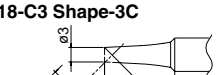
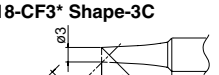
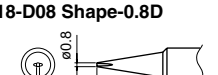
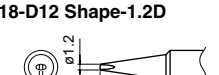
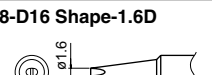
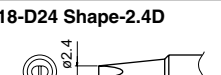
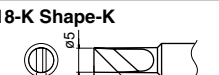
Unit: mm

 				
 T18-B Shape-B	 T18-C05 Shape-0.5C	 T18-C1 Shape-1C	 T18-CF1* Shape-1C	 T18-C2 Shape-2C
B3662 Nozzle assembly A	B3664 Nozzle assembly C	B3664 Nozzle assembly C	B3664 Nozzle assembly C	B3662 Nozzle assembly A
 T18-CF2* Shape-2C	 T18-C3 Shape-3C	 T18-CF3* Shape-3C	 T18-D08 Shape-0.8D	 T18-D12 Shape-1.2D
B3662 Nozzle assembly A	B3663 Nozzle assembly B	B3663 Nozzle assembly B	B3662 Nozzle assembly A	B3662 Nozzle assembly A
 T18-D16 Shape-1.6D	 T18-D24 Shape-2.4D	 T18-K Shape-K	 T18-I Shape-I	
B3663 Nozzle assembly B	B3663 Nozzle assembly B	B3665 Nozzle assembly D	B3664 Nozzle assembly C	
				* These tips are tinned on the soldering surface only.

Temperature Adjustable Soldering Iron

HAJKO FX-600 SOLDERING IRON

Temperature Adjustable Soldering Iron

Tip included



- Adjustable temperature range: 200 to 500°C

HAJKO FX-601 STAINED GLASS

Heavy Duty Temperature Adjustable Soldering Iron

Tip included



- Maximum temperature: 540°C

Features

Superior heat conductivity

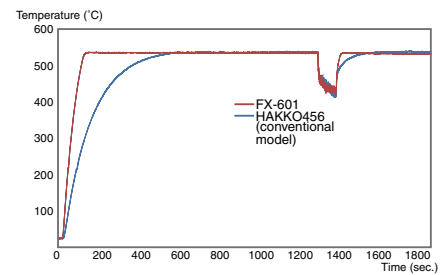
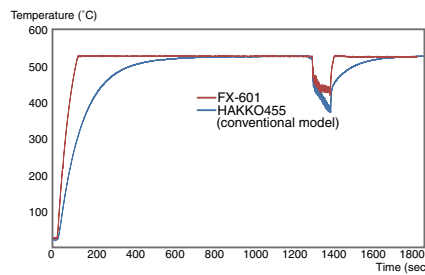
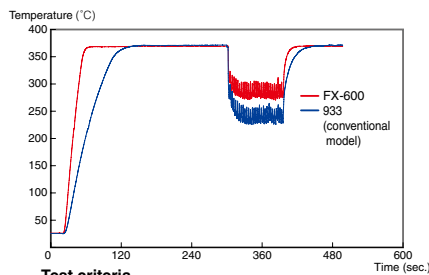

Test criteria

- Temperature of soldering iron with a diameter 1.6 x 5 mm piece of solder applied once every 3 seconds to paper phenol copper board.
- Lead-free solder is used.

Detach the control knob and lock the temperature setting.



Turn the CAL knob to attain a more accurate temperature.

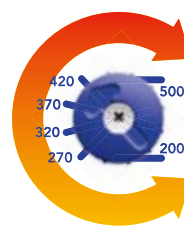

* Accurate temperature control can be performed even outside the scale.

Specifications

Model No.	FX-600	FX-601
Power consumption	50 W	47 W
Temperature range	200 to 500°C	240 to 540°C
Temperature stability	±1°C at idle temperature	±1°C at idle temperature
Tip to ground resistance	<2 Ω	<2 Ω
Tip to ground potential	<2 mV	<2 mV
Heating element	Ceramic heater	Ceramic heater
Standard tip	Shape-B (No. T18-B)	Shape-2B (No. T19-B2)
Total length*	233 mm (with B tip)	237 mm (with 2B tip)
Weight*	61 g (with B tip)	68 g (with 2B tip)

* Without cord

Packing List

FX-600	Unit, Lock key, Instruction manual
FX-601	Unit, Lock key, Instruction manual



FX-600 with 605M

Option

Part No.	Name	Specifications
633-01	Iron holder	With 599B
633-02	Iron holder	With cleaning sponge
605M	Iron cover	-
B3720	Tip enclosure	With nut, required when converting from the FX-600 to the FX-601
B3730	Nut and tip enclosure	Required when converting from the FX-601 to the FX-600

* For information on the iron holders, see P.47.

Replacement Tips for the FX-600

Unit: mm

T18-B Shape-B 	T18-BL Shape-BL 	T18-C05 Shape-0.5C 	T18-C08 Shape-0.8C 	T18-C1 Shape-1C
T18-C2 Shape-2C 	T18-C3 Shape-3C 	T18-C4 Shape-4C 	T18-C5 Shape-5C 	T18-CF1* Shape-1C
T18-CF15* Shape-1.5C 	T18-CF2* Shape-2C 	T18-CF3* Shape-3C 	T18-CF4* Shape-4C 	T18-CSF25* Shape-2.5CS
T18-D08 Shape-0.8D 	T18-D12 Shape-1.2D 	T18-D16 Shape-1.6D 	T18-D24 Shape-2.4D 	T18-D32 Shape-3.2D
T18-DL12 Shape-1.2DL 	T18-DL2 Shape-2DL 	T18-DL32 Shape-3.2DL 	T18-I Shape-I 	T18-BR02 Shape-0.2BR
T18-K Shape-K 	T18-S3 Shape-S3 	T18-S4 Shape-S4 	T18-S6 Shape-S6 	T18-S9 Shape-S9
T18-SB Shape-SB 	* These tips are tinned on the soldering surface only.			

Replacement Tips for the FX-601

Unit: mm

T19-B Shape-B 	T19-B2 Shape-2B 	T19-C3 Shape-3C 	T19-C4 Shape-4C 	T19-C65 Shape-6.5C
T19-D24 Shape-2.4D 	T19-D32 Shape-3.2D 	T19-D5 Shape-5D 	T19-D65 Shape-6.5D 	T19-I Shape-I

Ceramic Heater Soldering Iron

HAKKO DASH

SOLDERING IRON

Ceramic Heater Soldering Iron

Tip included



- Light-weight, compact soldering iron with ceramic heater
- Three types available in capacities of 15 W, 20 W and 25 W

Specifications

Model No.	N452	N453	N454
Power consumption	15 W	20 W	25 W
Heating element	Ceramic heater		
Standard tip	Shape-B (No. N452-T-B)		Shape-B (No. N454-T-B)
Insulation resistance	200 MΩ	100 MΩ	
Total length*	185 mm		192 mm
Weight*	47 g		57 g

* Without cord

Option

Part No.	Name	Specifications
633-01	Iron holder	With 599B
633-02	Iron holder	With cleaning sponge
606	Iron holder	With cleaning sponge
609	Iron holder	With cleaning sponge

* For information on the iron holders, see P.47.

Replacement Tips

Unit: mm

For N452, N453

N452-T-B Shape-B 	N452-T-1C Shape-1C 	N452-T-1CF* Shape-1C 	N452-T-2C Shape-2C
N452-T-2CF* Shape-2C 	N452-T-3C Shape-3C 	N452-T-3CF* Shape-3C 	N452-T-4C Shape-4C
N452-T-4CF* Shape-4C 	N452-T-C Shape-C 	N452-T-D Shape-D 	N452-T-I Shape-I
N452-T-SB Shape-SB 	N452-T-SC Shape-SC 	N452-T-SD Shape-SD 	<p>* These tips are tinned on the soldering surface only.</p>

For N454

N454-T-B Shape-B 	N454-T-2C Shape-2C 	N454-T-2CF* Shape-2C 	N454-T-3C Shape-3C
N454-T-3CF* Shape-3C 	N454-T-4C Shape-4C 	N454-T-4CF* Shape-4C 	N454-T-5C Shape-5C
N454-T-5CF* Shape-5C 	N454-T-D Shape-D 	N454-T-I Shape-I 	<p>* These tips are tinned on the soldering surface only.</p>

HAKKO PRESTO

SOLDERING IRON

W-Switchable Ceramic Heater Soldering Iron

Tip included



- The boost switch can immediately raise the power from 20 W in normal operation mode to 130 W, which enables the soldering iron to be heated up at a high speed.
- The HAKKO Presto can be used for a wide range of applications.
- A safety cap is available for 984 and 985.

When capped



Packing List

980, 981	Unit
984, 985	Unit, Safety cap

Specifications

Model No.	980	981	984	985
Power consumption	20/130 W (while the switch is pushed)			
Heating element	Ceramic heater			
Standard tip	Shape-B (No. 980-T-B)			
Total length*	205 mm	160 mm	205 mm	160 mm
Weight*	48 g	92 g	56 g	100 g

* Without cord and cap

Option

Part No.	Name	Specifications
633-01	Iron holder	With 599B
633-02	Iron holder	With cleaning sponge
606	Iron holder	With cleaning sponge
609	Iron holder	With cleaning sponge

* For information on the iron holders, see P.47.

Replacement Tips

Unit: mm

980-T-B Shape-B	980-T-BC Shape-BC	980-T-BI Shape-BI	980-T-D Shape-D

HAJKO FX-901 CORDLESS IRON

Battery-Powered Soldering Iron

Tip included



- Easy-to-carry soldering iron powered by AA alkaline batteries
- Cordless design makes this iron very handy and usable virtually anywhere.



Easy Replacement

Easy tip replacement

Turn the nipple
90° clockwise.



Easy battery replacement



Packing List

FX-901	Unit, Cap
--------	-----------

* Batteries not included

Specifications

Model No.	FX-901
Power supply	AA × 4 pcs
Power consumption	Alkaline batteries: 6 W (6 V) Nickel hydrogen batteries (2150 mAh): 5 W (4.8 V)
Standard tip	Shape-B (No.T11-B)
Battery life*	Alkaline batteries: 60 minutes Nickel hydrogen batteries (2150 mAh): 120 minutes
Total length**	212 mm
Weight***	76 g

Measurement conditions

- When using new batteries, performance will vary depending on the batteries.
- The operating time was measured from the point that the soldering iron was turned on to the point at which the temperature dropped below 300°C, which is the minimum temperature at which soldering can be performed.

* When using batteries other than those specified above, the performance and the operating time will vary.

** Without cap

*** Without battery

Replacement Tips for the FX-901

Unit: mm

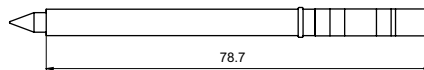

T11-B Shape-B

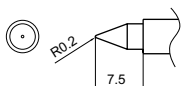

T11-D4 Shape-4D

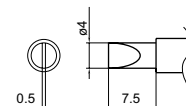

HAKKO RED SOLDERING IRON

Nichrome Heater Soldering Iron

Tip included



- Ideal for use in a variety of soldering works



Option

Part No.	Name	Specifications
602	Iron holder	With cleaning sponge
603	Iron holder	With cleaning sponge

* For information on the iron holders, see P.47.

Specifications

Model No.	500	501	502	503
Power consumption	20 W	30 W	40 W	60 W
Heating element	Nichrome heater			
Standard tip	ø3 × 65 mm (No.BB3)	ø4 × 70 mm (No.BB4)	ø6 × 85 mm (No.BB6)	
Total length*	199 mm	207 mm	248 mm	
Weight*	60 g	65 g	95 g	

* Without cord

HAKKO MG SOLDERING GUN

Solder Feed Soldering Gun

Tip included



- Solder feed mechanism built in the body allows users to make fine adjustments.



Specifications

Model No.	582	583	585	587	589	592
Power consumption	30 W	40 W	60 W	80 W	100 W	150 W
Heating element	Nichrome heater					
Standard tip	ø4 mm (No.582-T4)	ø6 mm (No.585-T6)	ø8 mm (No.587-T8)	ø10 mm (No.592-T10)		
Dimensions	197 x 149 mm	213 x 149 mm	227 x 149 mm	241 x 149 mm		
Weight*	266 g	290 g	318 g	322 g	380 g	

* Without cord

Packing List

582, 583, 585, 587, 589, 592	Unit, 1.6 mm diameter Guide nozzle, Instruction manual
-------------------------------------	--

* A 2.3 mm diameter guide nozzle is originally set into the unit.

Option

Part No.	Name	Specifications
582-N-0.8	Guide nozzle	0.8 mm
582-N-1.0	Guide nozzle	1.0 mm
582-N-1.2	Guide nozzle	1.2 mm
607	Iron holder	With cleaning sponge
582-022	Spool holder	—

* For information on the iron holder, see P.47.

HAKO FX-301B

SOLDERING POT

High Performance Soldering Pot

Digital



- Digital display ensures reliable temperature control and realizes precise temperature adjustment.
- Soldering pot is coated in a special long-life material, which is best suited for lead-free solder. This is provided as a standard feature.

HAKO FX-300

SOLDERING POT

High Performance Soldering Pot

Analog



- Temperature can be adjusted just by turning a knob during operation.
- Adding an optional specially coated stainless-steel pot provides compatibility with lead-free solder.

Quick heat up

Time comparison to reach set temperature FX-301B vs. 96 (conventional model)

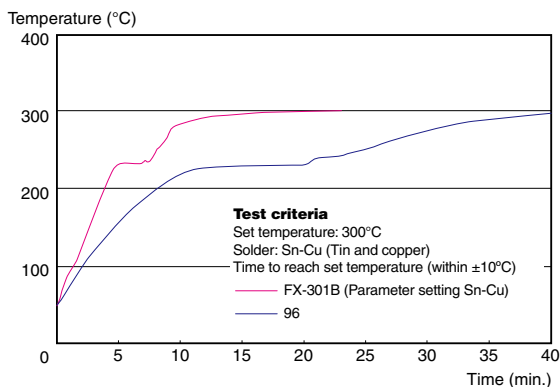

FX-300 vs. 96 (conventional model)

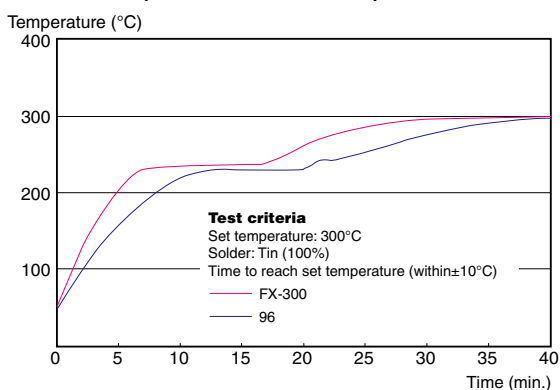

Easy Pot Replacement



Loosen the screw on both sides.



Change the pot and tighten the screws.

* For your safety, be sure to replace the pot after the solder completely cools.

Specially Coated Solder Pot (Durable type)

The special coating prevents the solder pot from corroding, which ensures that the solder pot has a long service life.



Standard solder pot



Specially coated solder pot

Packing List

FX-301B	Unit (with solder pot, 50 × 50 durable type), Spatula, J-shaped waste collector, Hexagon wrench, Instruction manual
FX-300	Unit (with solder pot, 50 × 50), Spatula, J-shaped waste collector, Hexagon wrench, Instruction manual

Specifications

Model No.	FX-301B
Power consumption	200 W (100 V), 260 W (110 V), 290 W (120 V), 240 W (220 V), 260 W (230 V), 280 W (240 V)
Dimensions	143 (W) × 100 (H) × 220 (D) mm
Weight*	1.7 kg

• Pot

Temperature range	50 × 50 square: 200 to 450°C 75 × 75 square: 200 to 380°C
Dimensions of solder pot	50 × 50 square durable type: 50 (W) × 43.5 (H) × 50 (D) mm 75 × 75 square durable type: 75 (W) × 52.5 (H) × 75 (D) mm
Molten solder capacity**	50 × 50 square: 0.85 kg 75 × 75 square: 1.2 kg

Model No.	FX-300
Power consumption	195 W (100 V), 220 W (110 V), 200 W (120 V), 190 W (220 V), 205 W (230 V), 215 W (240 V)
Dimensions	143 (W) × 100 (H) × 220 (D) mm
Weight*	1.7 kg

• Pot

Temperature range	50 × 50 square: 200 to 450 °C 75 × 75 square: 200 to 380 °C
Dimensions of solder pot	50 × 50 square durable type: 50 (W) × 43.5 (H) × 50 (D) mm 75 × 75 square durable type: 75 (W) × 52.5 (H) × 75 (D) mm
Molten solder capacity**	50 × 50 square: 0.85 kg 75 × 75 square: 1.2 kg

* Without solder and cord

** The 50 × 50 square solder pot is originally installed. The 75 × 75 square solder pot is an optional part.

Option / Replacements

Part No.	Name	Specifications
A1539	Solder pot	50 × 50 durable type
A1540	Solder pot	75 × 75 durable type
A1517	Solder pot	50 × 50
A1518	Solder pot	75 × 75
A1310	Temperature probe	For solder bath and pot

Dimensions of Solder Pot

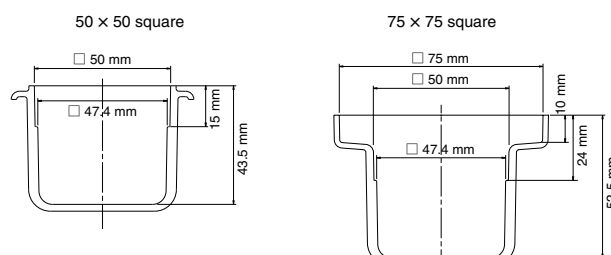

Soldering Pot/Flow Soldering System

HAKKO 96 SOLDERING POT

Soldering Pot



- Temperature can be adjusted just by turning a knob during operation.

Features

Dimensions of Solder Pot

50 x 50 square

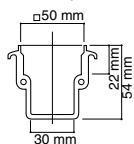

70 x 70 square

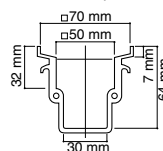

Operation



Packing List

96, 96-1	Unit, Spatula, Instruction manual
----------	-----------------------------------

Specifications

Part No.	96	96-1
Power consumption	200 W	
Dimensions	135 (W) x 105 (H) x 224 (D) mm	135 (W) x 120 (H) x 224 (D) mm
Weight*	1.5 kg	1.6 kg

* Without cord

•Pot

Temperature range	100 to 450°C	100 to 380°C
Dimensions of solder pot	50 (W) x 54 (H) x 50 (D) mm	70 (W) x 64 (H) x 70 (D) mm
Molten solder capacity	0.85 kg	1.2 kg

HAKKO 485 SOLDERING SYSTEM

Flow Soldering System



- Compatible with lead-free solder
- The impeller and chamber, which are the parts that corrode most easily, are plated with corrosion-resistant material.
- Both temperature and time are used to control the solder flow.

Dimensions

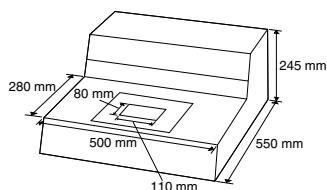

Packing List

485

Main unit, Air unit, Lamp (10 W [6 V]), Horizontal gauge, Spatula, IC tweezers, Waste collector, Positioning board, Foot switch, Locator light, Anti-oxidizer, 42-pin nozzle, 28-pin nozzle, 18/20-pin nozzle, 14/16-pin nozzle, 42-pin air hood, 28-pin air hood, 18/20-pin air hood, 14/16-pin air hood, Instruction manual

* Solder is not included.

Specifications

Model No.	485
Power consumption	850 W
Temperature range	Room temperature to 299°C
Molten solder capacity	10 kg
Dimensions	500 (W) x 245 (H) x 550 (D) mm
Weight*	35 kg

•Air unit

Air pressure	196 to 686 kPa (2 to 7 kgf/cm ²)
Dimensions	150 (W) x 100 (H) x 300 (D) mm
Weight**	3.5 kg

* Without solder and cord

** Without cord

Thermal Wire Stripper

HAKKO FT-801 ESD SAFE THERMAL WIRE STRIPPER

Thermal Wire Stripper

Blade not included



- Thermal wire stripper that ensures clean-cut removal of wire insulation
- High stripping performance ensures clean cut through highly heat-resistant PTFE.

Features

Solves the problem of whiskers and scratches being left by conventional tools

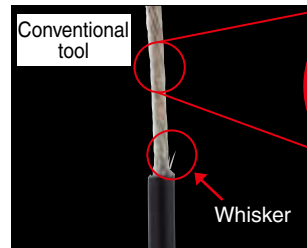

Whisker

Replacement Blades

For FT-8002

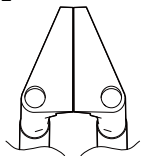

G2-1601 Wire stripper blade
Straight

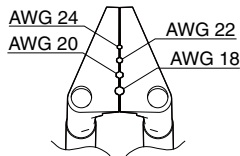

G2-1602 Wire stripper blade
AWG 18 to 24

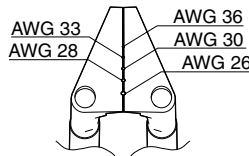

G2-1603 Wire stripper blade
AWG 26 to 36

For FT-8003 (option)

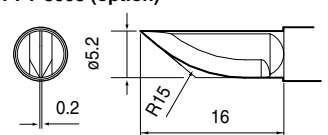

G3-1601 Knife type blade

Packing List

FT-801	Station, Handpiece (FT-8002), Power cord, Handpiece holder, Connecting cable, Lead adjuster, Blade removal tool, Instruction manual
--------	---

Option

Part No.	Name	Specifications
FT8003-01	HAKKO FT-8003 conversion kit	Handpiece (FT-8003), Knife blade, Handpiece holder, Instruction manual



Blade included



Specifications

Model No.	FT-801
Power consumption	68 W
• Station	
Output voltage	AC 24 V
Dimensions	80 (W) × 130 (H) × 131 (D) mm
Weight*	1.2 kg
• Handpiece	
Power consumption	64 W (24 V)
Cord length	1.3 m
Total length**	96 mm
Weight**	48 g

* Without cord

** Without cord and blade

HAKKO 153·154 LEAD FORMER

Lead Cutter and Former



- Lead cutter and former for axial components
- Can be used for forming and cutting, forming only, or cutting only

Cutting and Forming

HAKKO 153	HAKKO 154
<p>Cutting and forming</p>	<p>Cutting and forming</p>
<p>Forming</p>	<p>Forming</p>
<p>Cutting</p>	<p>Cutting</p>

Packing List

153, 154	Unit, Parts tray, Clamp, Handle, 2.0 mm Hexagon wrench, 2.5 mm Hexagon wrench, 3.0 mm Hexagon wrench, 4.0 mm Hexagon wrench, Instruction manual
-----------------	---

Specifications

Part No.	153-1	154-1
Forming size	5.6 mm pitch	5 mm pitch
Max. diameter of lead wire	ø0.8 mm (max.)	ø0.5 mm (max.)
Lead wire*	For annealed copper lead wire only	
Outer width of tape	85 mm (max.)	
Taping pitch	5 mm	
Dimensions	125 (W) × 130 (H) × 110 (D) mm	
Weight**	2 kg	

* These tools are not suited to work on components with lead frames (multiangular lead).
** Including handle and clamp

HAKKO 155 LEAD CUTTER

Lead Cutter



- Lead cutter for radial components

Cutting

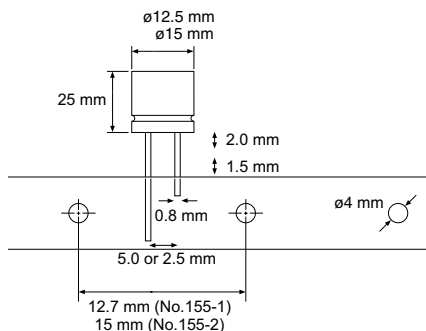

* Cutting only

Packing List

155	Unit, Parts tray, Clamp, Handle, 2.0 mm Hexagon wrench, 2.5 mm Hexagon wrench, 3.0 mm Hexagon wrench, 4.0 mm Hexagon wrench, Instruction manual
------------	---

Specifications

Part No.	155-1	155-2
Max. diameter of lead wire	ø0.8 mm (max.)	
Lead wire*	For annealed copper lead wire only	
Max. processing part size	ø12.5 × 25 mm (max.)	
Feed hole pitch	12.7 mm	15 mm
Lead pitch**	5.0 mm, 2.5 mm	5.0 mm
Min. processing size	1.5 mm from taping end, 2.0 mm from component end	
Dimensions	110 (W) × 140(H) × 125 (D) mm	
Weight***	1.7 kg	

* These tools are not suited to work on components with lead frames (multiangular lead).

** When shipped, the unit is set for components with a lead pitch of 5.0 mm.

*** Including handle and clamp

HAKKO 152B

MOTOR DRIVE

Motor Drive



Lead cutter or former is not included in the HAKKO 152B.



- Motor drive that enables automatic cutting and forming of taped components
- Constant-torque drive ensures precise and speedy processing.
- Speed control knob enables the adjustment of the processing speed.

Packing List

152B	Unit, Instruction manual
------	--------------------------

Specifications

Model No.	152B
Power consumption	30 W
Max. processing capacity (with HAKKO 153, 154)	36,000 pcs/hr
Max. processing capacity (with HAKKO 155)	18,000 pcs/hr
Dimensions	430 (W) × 150 (H) × 140 (D) mm
Weight*	5.6 kg

* Without cord

HAKKO DIPLINER

LEAD STRAIGHTENER

Lead Straightener

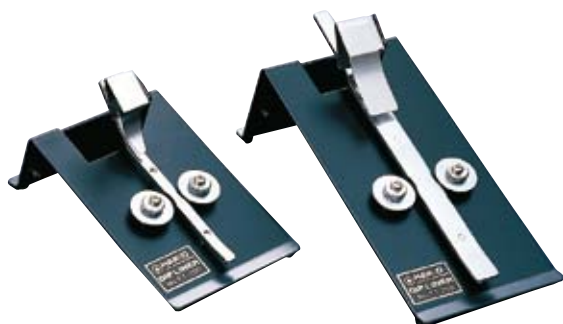

- IC lead liner for correcting variable lead pitches
- Simple mechanism enables the adjustments with just one screw.
- Simply insert the IC case into the chute.

Packing List

FT100, FT150, FT200, FT300	Unit, Instruction manual
----------------------------	--------------------------

Specifications

Part No.	FT100	FT150	FT200	FT300
Width of IC	7.5 mm	10 mm	15 mm	19 mm
Number of IC leads	8, 14, 16, 18, 20	22	24, 28, 40, 42	64

HAKKO FT-710 ESD SAFE TIP CLEANER

Solder-Splash-Preventing Rotary Tip Cleaner







- The solder removal level can be adjusted using two different types of brushes.
- Brushes can be replaced without using any tools, and safe design prevents solder waste from entering the drive part.

Features

Solder-Splash prevention



Controllable solder removal level

Brush	Cleaning brush A (standard accessory)	Cleaning brush B (optional)
Material	Resin 	Metal 
Image after cleaning	Some solder remains. 	Solder is completely removed. 
Benefit	Prevents tip oxidation and extends the service life of the tip	Suitable for soldering small sections that require control over the amount of solder.

Minimizes decrease in temperature of the tip during cleaning

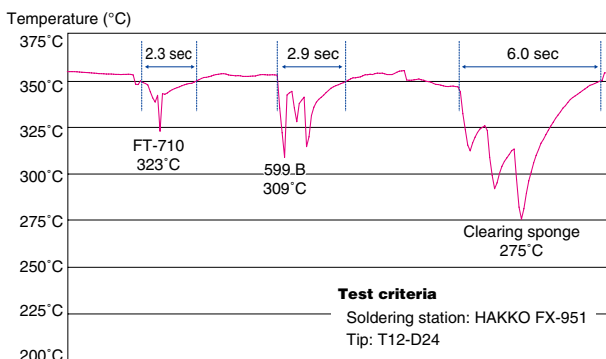

Packing List

FT-710	Unit, AC adapter, Receptacle A, Receptacle B, Lock nut, Gauge, Instruction manual
--------	---

Specifications

Model No.	FT-710
Power consumption	5 W
Standard receptacle	Receptacle A and B
Dimensions	71 (W) × 77 (H) × 107 (D) mm
Weight	0.45 kg

• AC adapter

Motor rating	DC 24V 130 mA
Dimensions	45 (W) × 40 (H) × 65 (D) mm
Weight	0.25 kg

• Compatibility table

Tip	Receptacle A	Receptacle B	Receptacle C
T12, T11	✓		
T18, 900M, T14		✓	
T10, T20, T13, T17, T22			✓

* This cleaner cannot be used with the T12-JL02, quad type, tunnel type, and spatula type soldering tips of the T12 series.

* There are some tips with dimensions that cannot be adjusted with the standard receptacles. In this situation, consult your nearest HAKKO dealer or distributor.

Option

Part No.	Name	Specifications
A1567	Cleaning brush B	Metal brushes, set of 2
B3519	Receptacle C	—

HAKO FT-700

TIP POLISHER

Tip Polisher



- Soldering tip polisher best suited to the removal of oxidation on soldering tips
- Prevents the shortening of the service life of tips caused by oxidation.

Usage

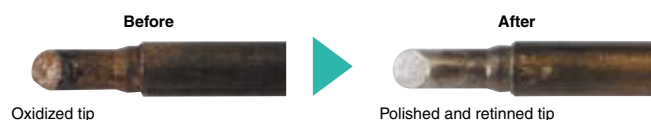

Oxidized tip

Polished and retinned tip

Cleaning procedure

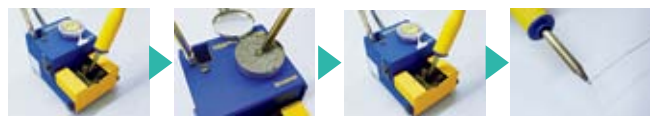

1. Remove the oxidation.

2. Quickly retin the tip.

3. Remove the chemical paste attached to the tip end.

4. Feed the solder wire to the tip.

* Approximately 300°C is the most suitable temperature for cleaning the tips.

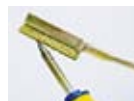

Use the brush to remove tough oxide.

Packing List

FT-700	Unit, Paste, Brush, Instruction manual
--------	--

Specifications

Model No.	FT-700
Power consumption	3 W (100 V), 4.5 W (110-120 V, 220-240 V)
Dimensions	70 (W) × 54 (H) × 101 (D) mm
Weight*	0.65 kg

* Without cord

• Chemical paste

Amount	10 g
Ingredients	Flux, tin (Sn) 50 wt% (each)

* The flux component of chemical paste consists of alicyclic amine hydrobromate, aliphatic amine hydrobromate, petrolatum, and wax.

HAKO FS-100

CHEMICAL PASTE

Chemical Paste



- Chemical paste best suited to the removal of oxidation on soldering iron tips
- Also used for retinning of soldering tips

Packing List

FS-100	Paste, Instruction manual
--------	---------------------------

Specifications

• Chemical paste

Amount	10 g
Ingredients	Flux, tin (Sn) 50 wt% (each)

* The flux component of chemical paste consists of alicyclic amine hydrobromate, aliphatic amine hydrobromate, petrolatum, and wax.

HAJKO 373 SELF FEEDER ESD SAFE

Self Feeder



- Automatic solder feeder that enables a user to complete soldering work with just one hand
- The solder feed time and speed can be set.

Set-Up Example

•Soldering for one-handed operation

Soldering irons + HAKKO 373 + Solder diameter adjustment ring + Tube unit with switch or + Guide pipe assembly or

* See the applicable soldering irons in the P.45.

Set-up example

•Soldering with a feeder pen

Soldering irons + HAKKO 373 + Solder diameter adjustment ring + Feeder pen + Switch Foot switch or Feeder switch

* Compatible with all soldering irons

Set-up example

Specifications

Model No.	373
Power consumption	6 W
Solder feed time	0 to 7 seconds (auto mode)
Solder feed speed	4.5 to 26 mm/sec.
Solder feed quantity	0 to 182 mm
Solder return quantity	0 to 5 mm (fixed speed)
Mode	Auto and manual
Usable solder diameter*	0.6, 0.65, 0.8, 1.0, 1.2, 1.6 mm
Usable solder quantity	1 kg or less
Dimensions	107 (W) × 110 (H) × 215 (D) mm
Weight**	1.5 kg

* ϕ 1.6 mm lead free solder can't be used.

** Without cord



Packing List

373	Unit, Instruction manual
-----	--------------------------

The accessories that are required for initial set-up, such as a tube unit, guide pipe assembly, and solder diameter adjustment ring, are not included. They must be ordered separately and adapted to use with the soldering iron and solder wire diameter.

Accessory Selection Guide

■ One-handed operation

Applicable soldering iron	Solder feed unit	Solder diameter	Options		
			Solder diameter adjustment ring	Guide pipe assembly	Tube unit
FM-2027 FM-2028 	373	0.6, 0.65 mm	 B1626	 or 	 or 
		0.8 mm	B1627	B3482	
		1.0 mm	B1628	B3483	
		1.2 mm	B1629	B3484	B3478
FM-2030 	373	0.6, 0.65 mm	B1626	B3726	
		0.8 mm	B1627	B3727	
		1.0 mm	B1628	B3728	
		1.2 mm	B1629	B3729	B3478
FX-8301 	373	0.6, 0.65 mm	B1626	B3566	
		0.8 mm	B1627	B3567	
		1.0 mm	B1628	B3568	
		1.2 mm	B1629	B3569	
		1.6 mm	B1630	B3570	
FX-8801 907 	373	0.6, 0.65 mm	B1626	B2146	
		0.8 mm	B1627	B2147	
		1.0 mm	B1628	B2148	
		1.2 mm	B1629	B2149	
		1.6 mm	B1630	B2150	
908 	373	0.6, 0.65 mm	B1626	B2151	
		0.8 mm	B1627	B2152	
		1.0 mm	B1628	B2153	
		1.2 mm	B1629	B2154	
		1.6 mm	B1630	B2155	
Dash (N452) (N453) 	373	0.6, 0.65 mm	B1626	B1674	
		0.8 mm	B1627	B1675	
		1.0 mm	B1628	B1676	
		1.2 mm	B1629	B1677	
		1.6 mm	B1630	B1678	
Dash (N454) 	373	0.6, 0.65 mm	B1626	B1679	
		0.8 mm	B1627	B1680	
		1.0 mm	B1628	B1681	
		1.2 mm	B1629	B1682	
		1.6 mm	B1630	B1683	

■ Feeder pen

Applicable soldering iron	Solder feed unit	Solder diameter	Options		
			Solder diameter adjustment ring	Feeder pen	Switch
Compatible with all soldering irons	373	0.6, 0.65 mm	 B1626		 or 
		0.8 mm	B1627		
		1.0 mm	B1628		
		1.2 mm	B1629		
		1.6 mm	B1630	C1235	

HAKKO 375 SELF FEEDER

V-Groove Maker



- Cutting a V-groove put on the solder surface reduces the splash of solder and flux.
- The solder feed amount can be controlled by turning the switch on and off.
- Compact, space-saving automatic solder feeder

Features

Minimize solder and flux splash

Cutting a V-groove on the solder surface enables the release of gas pressure generated by the flux, thereby suppressing splash. The HAKKO 375 can cut a groove in only the solder needed, then helps to reduce the level of defectiveness.

Advantages of V-grooved solder

-Examination of solder and flux splash

Test criteria

Measurement method	Measure the amount of solder and flux splashing after solder is fed to the soldering iron
Temperature setting for soldering iron	350°C and 400°C
Solder	Lead-free (Sn-3Ag-0.5Cu) Halogen-contain in flux and halogen-free flux ø0.3 mm and ø1.0 mm
Solder feed length	50 mm

* The effect of solder and flux splashing prevention may differ under different operation conditions.

Solder cross-section view

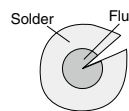

3D view

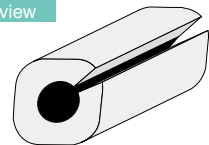

V-grooved solder

■ Amount of flux splashing (quantity of dots)

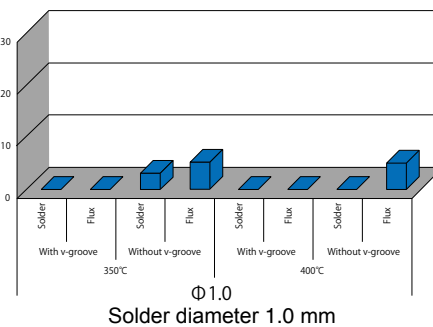
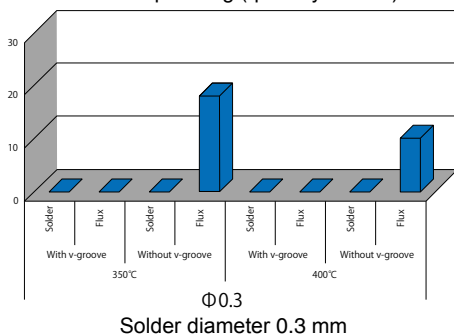

Packing List

375	Unit, AC Adapter, Instruction manual
-----	--------------------------------------

Option

Part No.	Name	Specifications
B1649	Foot switch	-
B2763	Hand switch	-

Specifications

Model No.	375
Rating	DC 24V 75 mA
Solder feed speed	27 mm/sec.
Usable solder diameter	0.3, 0.5, 0.6, 0.8, 1.0 mm
Dimensions	78 (W) × 98 (H) × 56 (D) mm
Weight	0.59 kg
•AC Adapter	
Motor rating	DC 24V 130 mA
Dimensions	45 (W) × 40 (H) × 65 (D) mm
Weight	0.25 kg

HAKKO CUTTING TOOL

Cutting Tool



- Designed for precision assembly of delicate, complex electronic work
- Soft-touch grip enables long tool usage for long periods at a time.
- Recommend for use in cutting copper and soft lead wires

Specifications

Part No.	Name	Max. copper wire cutting capability	A	B	C	D	E
106-01	Cutting tool for flush cut with safety clip	1.3 mm	132	54	13.5	5	20
106-02	Cutting tool for flush cut with angled blade	1.3 mm	129	54	13.5	5	16
106-03	Cutting tool for flush cut with small blade	0.8 mm	130	54	9.5	4	18
106-04	Cutting tool for a front, flush cut	1.0 mm	138	54	14	6	27
106-05	Cutting tool for flush cut	1.3 mm	132	54	13.5	5	20
106-06	Short nose pliers	–	140	54	13	6	29
106-07	Long nose pliers	–	154	54	13	6	40
106-08	Bent nose pliers	–	146	54	13	4	35

(Unit: mm)

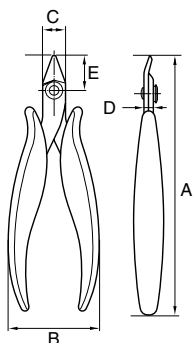

HAKKO IRON HOLDER

Iron Holder



No.633-01



No.633-02



No.606



No.609



No.607

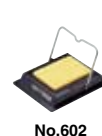

No.602



No.603



Wire-type tip cleaner



No.599B

HAKKO 599B

Prevents soldering tip oxidation



Applicable Soldering Irons

Part No.	633-01	633-02	606	609	607	602	603
Soldering irons	DASH PRESTO FX-600 FX-601	DASH PRESTO FX-600 FX-601	DASH PRESTO FX-600 FX-601	DASH PRESTO	MG	RED	RED

HAKKO 611 ESD SAFE SOLDER REEL STAND

Reel Stand

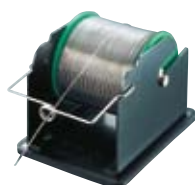

- Solder reel stand for coiled solder with a maximum load of 1 kg
- Smooth action when reeling out solder wire improves work efficiency
- A mounting screw for the grounding wire is attached on the baseplate.

Specifications

Part No.	611-1	611-2
Shaft diameter	ø15 mm	
Usable solder	Roll solder 1 kg (max.) × 1	Roll solder 1 kg (max.) × 2
Dimensions	86 (W) × 78 (H) × 141 (D) mm	87 (W) × 200 (H) × 141 (D) mm
Weight	450 g	750 g



No.611-2

Vacuum Pick-Up Tool

HAKKO392 ESD SAFE VACUUM PICK-UP

Outlet-Powered Type



- Outlet-powered suction pick-up tool with built-in vacuum pump
- The pick-up capacity can be increased up to 230 gf with an optional pad.

HAKKO393 VACUUM PICK-UP

Dropper Type



- Portable, easy-to-carry manual dropper-type vacuum pick-up
- Maximum pick-up capacity of 40 gf
- Uses antistatic material

HAKKO394 VACUUM PICK-UP

Battery-Powered Type



- Battery-powered suction pick-up tool with built-in vacuum pump
- Maximum pick-up capacity of 120 gf
- Uses antistatic material

Usage Example

HAKKO 392



HAKKO 393



HAKKO 394



With the bent nozzle accessory, 0603-size components can be picked up.



Replacement Pads and Nozzles

Part No.	Name	Specifications
A1164	Bent nozzle	0.4 mm
A1165	Bent nozzle	1.1 mm with stopper
A1198	Bent nozzle	0.26 mm
A1486	Straight nozzle	1.1 mm with stopper
A1166	Pad	3 mm
A1312	Pad	5 mm
A1167	Pad	7 mm
A1311	Pad	10 mm

Packing List

392	Unit, 0.4 mm diameter Bent nozzle, 1.1 mm diameter Bent nozzle, 3 mm diameter Pad, 7 mm diameter Pad, Instruction manual
393	Unit, 1.1 mm diameter Bent nozzle with stopper, 3 mm diameter Pad, 7 mm diameter Pad, 10 mm diameter Pad, Instruction manual
394	Unit, 1.1 mm diameter Bent nozzle with stopper, 5 mm diameter Pad, 10 mm diameter Pad, two AAA Alkaline batteries (for trial), Instruction manual

Specifications

Model No.	392
Power consumption	5 W
Maximum pressure	37.3 kPa (280 mmHg)
Pad	Conductive silicone rubber
Dimensions	Station: 132 (W) × 83 (H) × 170 (D) mm Pen: ø10 × 123 (L) mm Hose: 1.1 m
Weight*	Station: 1.65 kg Pen: 25 g

* Without cord, nozzle and pad

Model No.	393
Pad	Conductive silicone rubber
Dimensions	ø13 mm × 132 mm
Weight*	19.2 g

* Without nozzle and pad

Model No.	394
Power supply	Two AAA batteries
Pad	Conductive silicone rubber
Battery life	Approx. 30,000 suction (with alkaline batteries)
Suction capacity	120 gf (with a pad diameter of 10 mm)
Dimensions	130 (W) × 29 (H) × 22 (D) mm
Weight*	43 g

* Without batteries, nozzle and pad

Desoldering Tool

HAKKO FM-204 ESD SAFE DESOLDERING TOOL

High-Power Desoldering Tool Digital

Nozzle not included



- Vacuum pump built-in type desoldering tool
- Digital display ensures easy and reliable temperature control.
- Sleep function that works with iron holder prevents nozzle oxidation.

Packing List

FM-204	Station, Iron holder, Ceramic paper filter (10 pcs), Cleaning drill for heating element, Filter pipe assembly (1 pc), Control card, Power cord, Connecting cable, Nozzle remover, Desoldering tool (FM-204), Handle for gun configuration, Instruction manual
---------------	---

Option

Part No.	Name	Specifications
FM2027-04	HAKKO FM-2027 conversion kit	70 W (24 V)
FM2026-05	HAKKO FM-2026 conversion kit	70 W (24 V)

Specifications

Model No.	FM-204
Power consumption	120 W
Temperature range	FM-2024: 350 to 450°C FM-2026/2027: 200 to 450°C
Temperature stability	±5°C at idle temperature

• Station

Output voltage	AC 24 V
Vacuum generator	Double cylinder type
Vacuum pressure	Max. 80 kPa (600 mmHg)
Suction flow*	15 L/min.
Dimensions	160 (W) × 120 (H) × 225 (D) mm
Weight	3.7 kg

• Desoldering Tool

Power consumption	70 W (24 V)
Nozzle to ground resistance	<2 Ω
Nozzle to ground potential	<2 mV
Heating element	Composite heater
Cord length	1.2 m
Total length**	180 mm (with ø1.0 mm nozzle)
Weight**	65 g (with ø1.0 mm nozzle)

* Measured at the filter case suction port of the station.

** Without cord and hose

Optional Nozzles

Unit : mm

N1-06 Nozzle 0.6 mm 	N1-08 Nozzle 0.8 mm 	N1-10 Nozzle 1.0 mm 	N1-13 Nozzle 1.3 mm
N1-16 Nozzle 1.6 mm 	N1-20 Nozzle 2.0 mm 	N1-23 Nozzle 2.3 mm 	N1-L10 Nozzle 1.0 mm Long

Features

Excellent thermal recovery

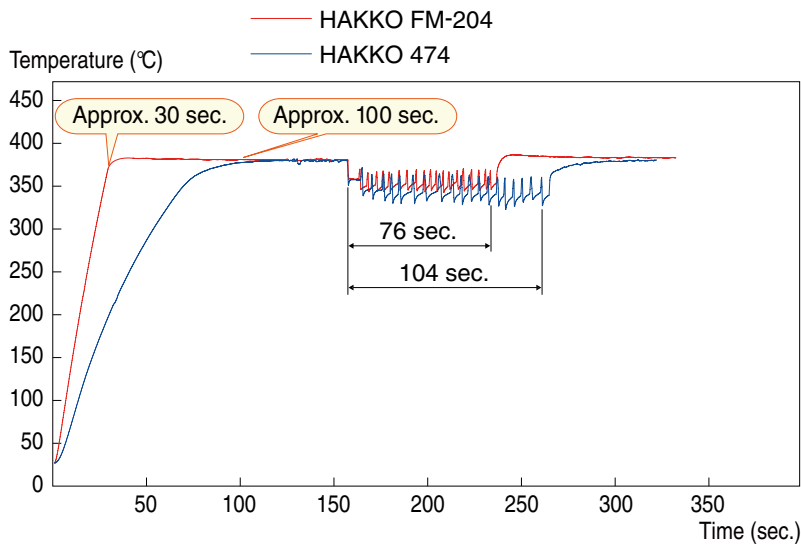

Test criteria

Measurement method	The time until the soldered portion reaches 200°C is measured for 20 points.
Nozzle used	ø1.0 mm
Solder	Lead-free solder

Two way use of grip part



Gun configuration



Straight configuration

Simple and safe nozzle replacement by the nozzle remover

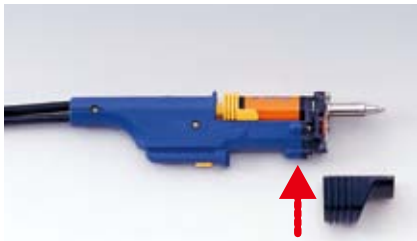

Sleep function and Auto Power Shut-off function

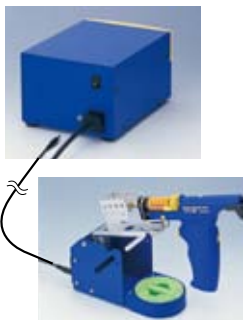

Connect the FM-204 station and FH-200 iron holder using a connecting cable.

Replacing the handpiece enables soldering.

■ Soldering



HAKKO FM-2027

■ N₂ System



Set-up example
 HAKKO FM-204
 HAKKO FM-2026
 HAKKO FX-780
 HAKKO FX-791

HAKKO 474 DESOLDERING TOOL ESD SAFE

Vacuum-Pump Type Desoldering Tool Analog

Nozzle included



- Vacuum pump built-in type that is easy to carry

HAKKO 475 DESOLDERING TOOL ESD SAFE

External-Air-Compressor Type Desoldering Tool Analog

Nozzle included



- External air compressor type that has a more powerful vacuum than HAKKO 474

Connection example

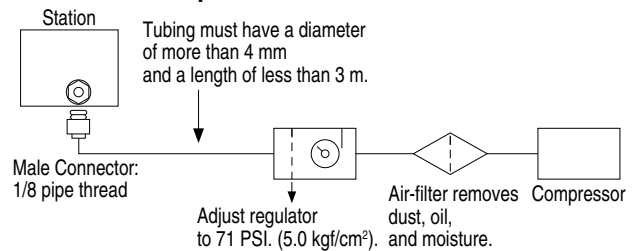

Handpiece Variations



HAKKO 809



HAKKO 815



HAKKO 816

Packing List

474, 475 (with 809)	Station, 809 Desoldering gun, Filter pipe, Ceramic paper filter (S; 2 pcs), Ceramic paper filter (L; 4 pcs), Spring filter (3 pcs), Cleaning pin for 1.0 mm diameter nozzle, Cleaning drill for 1.0 mm diameter nozzle, Cleaning pin for heating element, Cleaning pin holder, Wrench, Silicone grease, Iron holder base, Cleaning sponge, Spring iron holder, Instruction manual
474, 475 (with 815)	Station, 815 Desoldering tool, Filter pipe, Ceramic paper filter (S; 2 pcs), Ceramic paper filter (L; 4 pcs), Spring filter (3 pcs), Cleaning pin for 1.0 mm diameter nozzle, Cleaning drill for 1.0 mm diameter nozzle, Cleaning pin for heating element, Cleaning pin holder, Wrench, Silicone grease, Anti-seizure, Iron holder base, Cleaning sponge, Iron receptacle with holder, Instruction manual
474, 475 (with 816)	Station, 816 Desoldering gun, Filter pipe, Ceramic paper filter (S; 2 pcs), Ceramic paper filter (L; 4 pcs), Spring filter (3 pcs), Cleaning pin for 1.0 mm diameter nozzle, Cleaning drill for 1.0 mm diameter nozzle, Cleaning pin for heating element, Cleaning pin holder, Wrench, Silicone grease, Anti-seizure, Iron holder base, Cleaning sponge, Iron receptacle with holder, Instruction manual

Specifications

Model No.	474 (with 809)	474 (with 815)	474 (with 816)	475 (with 809)	475 (with 815)	475 (with 816)
Power consumption	100 W			70 W		
Temperature range	380 to 480°C					

•Station

Output voltage	AC 24 V					
Vacuum generator	Double cylinder type			Ejector type		
Vacuum pressure	Max. 80 kPa (600 mmHg)			Max. 93 kPa (700 mmHg)		
Suction flow*	15 L/min.			20 L/min.		
Applied air pressure	-			490 kPa (5.0 kgf/cm ²) While trigger or button is pressed		
Compressed air consumption	-			46 L/min.		
Dimensions	165 (W) × 135 (H) × 260 (D) mm					
Weight**	3.8 kg			3.0 kg		

•Desoldering Tool

Type	Gun	Pen	Gun	Gun	Pen	Gun
Power consumption	50 W (24 V)					
Nozzle to ground resistance	<2 Ω					
Nozzle to ground potential	<2 mV					
Heating element	Ceramic heater					
Standard nozzle	ø1.0 mm S type (No. A1003)	ø1.0 mm S type (No. A1499)		ø1.0 mm S type (No. A1003)	ø1.0 mm S type (No. A1499)	
Dimensions	135 (W) × 174 (H) mm	200 (W) × 80 (H) mm	180 (W) × 150 (H) mm	135 (W) × 174 (H) mm	200 (W) × 80 (H) mm	180 (W) × 150 (H) mm
Weight**	200 g	100 g	120 g	200 g	100 g	120 g

* Measured at the filter case suction port of the station.

** Without cord and hose



Replacement Nozzles

Unit : mm

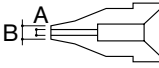
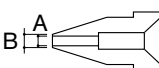
For 808 and 809

Part No.	Figure	Size	
		A	B
A1002		0.8	1.8
A1003		1.0	2.0
A1004		0.8	2.3
A1005		1.0	2.5
A1006		1.3	3.0
A1007		1.6	3.0

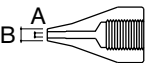
For 815 and 816

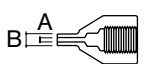
Part No.	Figure	Size	
		A	B
A1496		0.8	1.8
A1499		1.0	2.0
A1498		0.8	2.3
A1500		1.0	2.5
A1501		1.3	3.0
A1502		1.6	3.0
A1503		2.0	3.6
A1497		0.8	2.2

HAKKO 484 DESOLDERING TOOL

Desoldering Tool

Nozzle included



- Compact design enables portability.

Packing List

484	Station, Desoldering gun, Iron holder, Cleaning pin for heating core, Cleaning pin for 1.0 mm diameter nozzle, Cleaning wrench, Filter set (5 pcs), Anti-seizure, Silicone grease, Instruction manual
-----	---

Replacement Nozzles

Unit : mm

Part No.	Figure	Size	
		A	B
481-T-0.8		0.8	2.5
481-T-1.0		1.0	2.5
481-T-1.3		1.3	2.5
481-T-1.6		1.6	3.0

Specifications

Model No.	484
Power consumption	60 W
Nozzle temperature	370°C

•Station

Vacuum generator	Double cylinder type
Vacuum pressure	Max. 80 kPa (600 mmHg)
Suction flow	50 Hz: 10 L/min. 60 Hz: 12 L/min.
Dimensions	135 (W) × 75 (H) × 180 (D) mm
Weight*	2.5 kg

•Desoldering Gun

Insulation resistance	100 MΩ (370°C)
Heating element	Ceramic heater
Standard nozzle	ø1.0 mm (No. 481-T-1.0)
Weight**	230 g

* Without cord

** Without cord and hose

HAKKO 808 DESOLDERING TOOL

808

Portable Desoldering Tool Analog

Nozzle included



- High suction power for a portable unit

Packing List

808	Unit, Pre-filter (3 pcs), Ceramic paper filter (L; 4 pcs), Cleaning pin for 1.0 mm diameter nozzle, Cleaning pin for heating element, Wrench, Filter pipe with pre-filter and filter holder, Instruction manual
-----	---

For information on replacement nozzles, see P.53.

Specifications

Model No.	808
Power consumption	70 W (100-110 V, 220-230 V), 100 W (120 V, 240 V)
Temperature range	380 to 480°C
Nozzle to ground resistance	<2 Ω
Nozzle to ground potential	<2 mV
Vacuum generator	Double cylinder type
Vacuum pressure	Max. 80 kPa (600 mmHg)
Suction flow	10 L/min.
Heating element	Ceramic heater
Standard nozzle	ø1.0 mm (No. A1005)
Dimensions	235 (W) × 170 (H) mm
Weight*	420 g

* Without cord

HAKKO SPPON

DESOLDERING TOOL

Desoldering Tool

Nozzle included



- Light-weight and simplified desoldering tool with high suction power
- Use a cleaning shaft that enables the nozzle to be cleaned after each use
- Nozzles can be easily replaced.

Replacement Nozzles

Unit : mm

Part No.	Figure	Adaptation products
18-N		No.18, 18G
20-N		No.20, 20G
DS01-N		No.DS01P

Specifications

Part No.	Absorption capacity
18	12 cm ³ (12 cc)
18G	12 cm ³ (12 cc) with guard
20	20 cm ³ (20 cc)
20G	20 cm ³ (20 cc) with guard
DS01P	28 cm ³ (28 cc)

HAKKO WICK

DESOLDERING WIRE

Desoldering Wire



- Handy for removing solder after dismantling surface-mounted components

Features

Through-hole solder removal



Bridging solder removal



Specifications

Regular type (Flux)

Part No.	Description
FR100-00	1.5 m × 0.6 mm
FR100-01	1.5 m × 0.9 mm
FR100-02	1.5 m × 1.4 mm
FR100-03	1.5 m × 1.9 mm
FR100-04	1.5 m × 2.5 mm
FR100-05	1.5 m × 3.3 mm

Unflux type (Unflux)

Part No.	Description
FR110-00	1.5 m × 0.6 mm
FR110-02	1.5 m × 1.4 mm
FR110-03	1.5 m × 1.9 mm
FR110-04	1.5 m × 2.5 mm
FR110-05	1.5 m × 3.3 mm

No clean type (Low residue flux) ESD SAFE package

Part No.	Description
FR120-00	1.5 m × 0.6 mm
FR120-01	1.5 m × 0.9 mm
FR120-02	1.5 m × 1.4 mm
FR120-03	1.5 m × 1.9 mm
FR120-04	1.5 m × 2.5 mm
FR120-05	1.5 m × 3.3 mm

HAKKO 701 ESD SAFE REPAIR SYSTEM

Repair System Analog

Tip included

Nozzle included



Soldering



Soldering (Option)



Desoldering



Hot Tweezer (Option)



- All-in-one repair system that enables both soldering and desoldering

Packing List

701	Station, Soldering iron (907), Desoldering gun (809), Filter pipe, Cleaning pin for 1.0 mm diameter nozzle, Cleaning pin for heating element, Cleaning drill for 1.0 mm diameter nozzle, Ceramic paper filter (S; 2 pcs), Ceramic paper filter (L; 4 pcs), Spring filter (3 pcs), Silicone grease, Wrench, Iron holder for soldering iron, Iron holder for desoldering gun, Instruction manual
-----	--

For information on replacement tips and nozzles, see our website (<http://www.hakko.com/>).

Specifications

Model No.	701
Power consumption	150 W
Temperature range	Soldering: 200 to 480°C Desoldering: 380 to 480°C

• Station

Output voltage	AC 24 V
Vacuum generator	Double cylinder type
Vacuum pressure	Max. 80 kPa (600 mmHg)
Suction flow	15 L/min.
Dimensions	190 (W) × 130 (H) × 250 (D) mm
Weight*	5 kg

• Soldering Iron

Power consumption	50 W (24 V)
Tip to ground resistance	<2 Ω
Tip to ground potential	<2 mV
Heating element	Ceramic heater
Standard tip	Shape-B (No. 900M-T-B)
Cord length	1.2 m
Total length*	222 mm (with B tip)
Weight*	44 g (with B tip)

• Desoldering Gun

Power consumption	50 W (24 V)
Nozzle to ground resistance	<2 Ω
Nozzle to ground potential	<2 mV
Heating element	Ceramic heater
Standard nozzle	ø1.0 mm S type (No. A1003)
Cord length	1.2 m
Dimensions**	135 (W) × 174 (H) mm
Weight**	200 g

* Without cord

** Without cord and hose

HAKKO 702B ESD SAFE REWORK SYSTEM

Rework System Analog

Tip included

Nozzle included



Soldering



Soldering (Option)



Desoldering



Hot Tweezer (Option)



Hot Air Reworking



- Multi-station that enables soldering, desoldering, and SMD rework all with a single unit

Packing List

702B	Station, Soldering iron (907 × 1 pc, 900S × 1 pc), Desoldering gun (809), Handpiece (hot air), Nozzle tray, Filter pipe, Cleaning pin for 1.0 mm diameter nozzle, Cleaning pin for heating element, Cleaning drill for 1.0 mm diameter nozzle, Ceramic paper filter (S; 2 pcs), Ceramic paper filter (L; 4 pcs), Spring filter (3 pcs), Silicone grease, Wrench, Iron holder for soldering iron (2 pcs), Iron holder for desoldering gun, Handpiece holder, FP pick-up with S and L wires, Nozzle for handpiece (hot air; A1124B × 1 pc, A1128B × 1 pc), Power cord, Instruction manual, Troubleshooting guide
-------------	--

For information on replacement tips and nozzles, see our website (<http://www.hakko.com/>).

Specifications

Model No.	702B
Power consumption	500 W
Temperature range	Soldering: 200 to 480°C Desoldering: 380 to 480°C SMD Rework: 100 to 420°C (use No. A1126B)

• Station

Output voltage	AC 24 V
Vacuum generator	Double cylinder type
Vacuum pressure	Max. 80 kPa (600 mmHg)
Suction flow	15 L/min.
Air flow	23 L/min. (max.)
Dimensions	360 (W) × 150 (H) × 266 (D) mm
Weight*	10 kg

• Soldering Iron

Power consumption	50 W (24 V) × 2 pcs
Tip to ground resistance	<2 Ω
Tip to ground potential	<2 mV
Heating element	Ceramic heater
Standard tip	Shape-B (No. 900M-T-B), Shape-I (No. 900S-T-I)
Cord length	1.2 m
Total length*	907-ESD: 222 mm (with B tip) 900S-ESD: 215 mm (with B tip)
Weight*	907-ESD: 44 g (with B tip) 900S-ESD: 29 g (with B tip)

• Desoldering Gun

Power consumption	50 W (24 V)
Nozzle to ground resistance	<2 Ω
Nozzle to ground potential	<2 mV
Heating element	Ceramic heater
Standard nozzle	ø1.0 mm S type (No. A1003)
Cord length	1.2 m
Dimensions**	135 (W) × 174 (H) mm
Weight**	200 g

• Handpiece (Hot Air)

Power consumption	250 W
Standard nozzle	No. A1124B and A1128B
Total length*	196 mm
Weight*	120 g

* Without cord

** Without cord and hose

HAKKO FR-870 PREHEATER ESD SAFE

IR Preheater Digital



- Infrared preheater that provides the optimal heating effect over the whole workpiece surface
- Short heatup time realized by the use of an infrared heater improves work efficiency.
- Non-contact system enables the application of this preheater to doublesided boards.

Mode Selection

Power Mode

Control heater output from 0% to 100%.

T/C Mode

Sense the temperature of the sensor attached to the board and control to maintain the set temperature for the board.



Auto Mode

Auto mode provides three steps (Step 1 to 3) to create an optimal heating profile for the workpiece.

With Power Mode

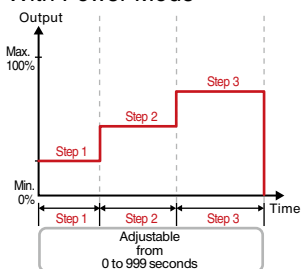

With T/C Mode

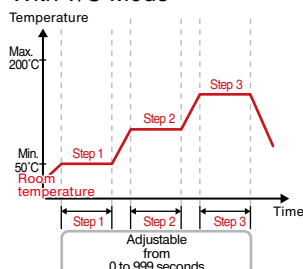

Packing List

FR-870	Unit, Thermocouple, Power cord, Heater lamp, Instruction manual
--------	---

Specifications

Model No.	FR-870
Power consumption	460 W (100 V), 520 W (110 V), 580 W (120 V), 1400 W (220 V), 1500 W (230 V)
Operation mode	Power mode, T/C mode Power auto mode, T/C auto mode
Setting range: Power mode	0 to 100%
Setting range: T/C mode	50 to 200°C
Setting range: Set time	0 to 999 seconds
Heating element	Halogen heater: 100 V, 110 V, 120 V Carbon heater: 220 V, 230 V
Effective heated area	190 (W) × 80 (D) mm
Heater area dimensions	248 (W) × 140 (D) mm
Work grid partitions	2
Temperature sensor	K-type thermocouple
Lamp lifetime*	2000 hours
Lamp control	Power mode: Percentage-based system T/C mode: PID control
External inputs	Start signal input possible
Dimensions	290 (W) × 100 (H) × 308 (D) mm
Weight**	3.4 kg

* Provided for reference purpose only and is not guaranteed.
** Without cord

HAKKO FR-830 ESD SAFE PREHEATER

Preheater **Analog**



- Compact pre-heater best suited for heat processing on localized areas
- Featuring quick heatup and less variations in temperature

Features

Preheating in a short time

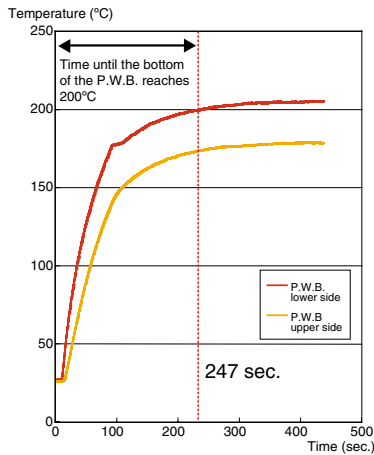

Test criteria

Measurement method	Temperature measured using sensors mounted on both the top and bottom surfaces of the P.W.B.
Distance between air outlet and P.W.B.	10 mm
Temperature setting	300°C

Set-up example



HAKKO FR-830
HAKKO FR-803B
REWORK FIXTURE
OMNIVISE
HAKKO FG-100

Packing List

FR-830	Unit, Power cord, Instruction manual
--------	--------------------------------------

Specifications

Model No.	FR-830
Power consumption	210 W (100 V), 240 W (110 V), 470 W (120 V), 230 W (220 V), 250 W (230 V), 270 W (240 V)
Air flow	0.15 m ³ /min. (fan capability)
Temperature range	150 to 300°C (Above the blow exit)
Dimensions*	140 (W) × 75 (H) × 185 (D) mm
Weight**	0.75 kg

* The height (H) is the distance from the bottom of the feet to the top of the exhaust outlet.
** Without cord

Option

Part No.	Name	Specifications
B3263	Extension pipe	with lid
B2763	Hand switch	—
B1649	Foot switch	—

HAJKO FR-801 SMD REWORK STATION ESD SAFE

Hot-Air SMD Rework Station **Analog**

Nozzle not included



- Equipped with a temperature offset function.

HAJKO FR-802 SMD REWORK STATION ESD SAFE

Hot-Air SMD Rework Station **Digital**

Nozzle not included



- Digital offset function enables variations in temperature between workpieces to be offset.

HAJKO FR-803B SMD REWORK STATION ESD SAFE

Hot-Air SMD Rework System **Digital**

Nozzle not included



- 3-step temperature profile (preheating, heating, and cooling down) is available.
- Vacuum function makes it possible to pick up workpieces.

Features

New mechanism for maintaining consistent temperature



On-off by handy switch (FR-802 and FR-803B)

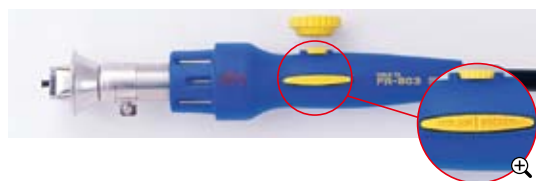

Settable 3-step temperature profile (FR-803B)

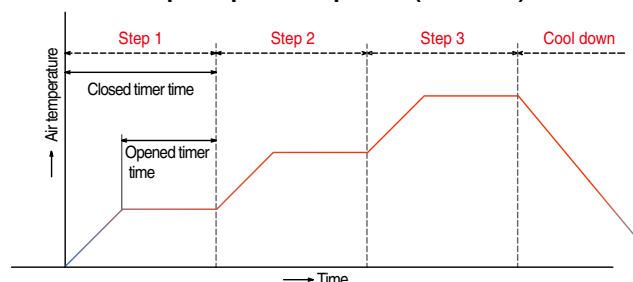

Built-in vacuum pickup (FR-803B)



Packing List

FR-801	Station with handpiece, Power cord, Handpiece holder, FP pick-up with S and L wire, Instruction manual
FR-802	Station with handpiece, Power cord, Control card, Handpiece holder, FP pick-up with S and L wire, Instruction manual
FR-803B	Station with handpiece, Power cord, Control card, Handpiece holder, Connecting cable, Pad (3 mm, 5 mm, 7.6 mm x 2 pcs each), Instruction manual

NOTE: This product does not come with a nozzle. When purchasing this product, be sure to order a nozzle suitable for the work to be done.

Option

Part No.	Name	Specification
C1541	Temperature probe	-

Controlling the temperatures of the hot air rework system and the workpiece using a temperature probe

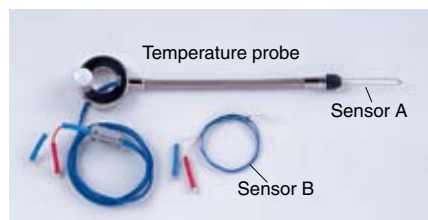

Set-up example 1 Set-up example 2 Set-up example 3



Specifications

Model No.	FR-801	FR-802	FR-803B
Power consumption	310 W (100 V) 360 W (110 V) 430 W (120 V) 570 W (220 V) 630 W (230 V) 680 W (240 V)		310 W (100 V) 370 W (110 V) 440 W (120 V) 590 W (220 V) 650 W (230 V) 700 W (240 V)
Temperature range	100 to 500°C (use No. A1130)		100 to 500°C (sensor)

• Station

Power consumption	30 W (stand-by power consumption: 4 W [100-120 V], 7 W [220-240 V])	30 W (stand-by power consumption: 4 W [100-120 V, 220-240 V])	30 W (100 V), 40 W (110-120 V), 50 W (220-240 V) (stand-by power consumption: 4 W [100-120 V, 220-240 V])
Air flow	5 to 20 L/min. (max.)	5 to 20 L/min. (max.)	5 to 20 L/min. (max.)
Operation mode	-	-	Auto or manual
Timer	-	-	50 files, 3 steps each
Dimensions*	160 (W) × 145 (H) × 230 (D) mm		
Weight*	4 kg	4.3 kg	5 kg

• Handpiece

Power consumption	280 W (100 V), 330 W (110 V), 400 W (120 V), 540 W (220 V), 600 W (230 V), 650 W (240 V)		
Total length*	185 mm	200 mm	200 mm
Weight*	115 g	200 g	200 g

* Without cord





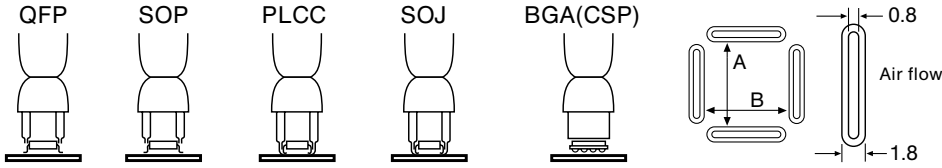









Optional Nozzles

Unit: mm













*The size in each description indicates the size of the package.









QFP and BQFP

A1125B QFP 10 × 10  A: 10.2 B: 10.2	A1262B QFP 12 × 12  A: 12.2 B: 12.2	A1126B QFP 14 × 14  A: 15.2 B: 15.2	A1128B QFP 14 × 20  A: 15.2 B: 21.2	A1127B QFP 17.5 × 17.5  A: 19.2 B: 19.2
A1261B QFP 20 × 20  A: 20.2 B: 20.2	A1129B QFP 28 × 28  A: 29.7 B: 29.7	A1263B QFP 28 × 40  A: 27.7 B: 39.7	A1265B QFP 32 × 32  A: 32.2 B: 32.2	A1203B QFP 35 × 35  A: 35.2 B: 35.2
A1264B QFP 40 × 40  A: 40.2 B: 40.2	A1215B QFP 42.5 × 42.5  A: 42.5 B: 42.5	A1180B BQFP 17 × 17  A: 18.2 B: 18.2	A1181B BQFP 19 × 19  A: 19.2 B: 19.2	A1182B BQFP 24 × 24  A: 24.2 B: 24.2



SOP and TSOL

A1131* SOP 4.4 × 10  4.8	A1132* SOP 5.6 × 13  5.7	A1133* SOP 7.5 × 15  7.2	A1134* SOP 7.5 × 18  7.2	A1258B SOP 7.6 × 12.7  8.2
A1260B SOP 8.6 × 18  8.7	A1257B SOP 11 × 21  11.7	A1259B SOP 13 × 28  13.5	A1185B TSOL 13 × 10  11.9	A1186B TSOL 18 × 10  18.2
A1187B TSOL 18.5 × 8  18.5				





PLCC

A1188B PLCC 9 × 9 (20 pins)  A: 11 B: 11	A1140B PLCC 11.5 × 11.5 (28 pins)  A: 13 B: 13	A1141B PLCC 11.5 × 14 (32 pins)  A: 15 B: 13	A1139B PLCC 12.5 × 7.3 (18 pins)  A: 9 B: 14	A1135B PLCC 17.5 × 17.5 (44 pins)  A: 18.5 B: 18.5
A1136B PLCC 20 × 20 (52 pins)  A: 21 B: 21	A1137B PLCC 25 × 25 (68 pins)  A: 26 B: 26	A1138B PLCC 30 × 30 (84 pins)  A: 31 B: 31	A1189B PLCC 34 × 34 (100 pins)  A: 36.5 B: 36.5	



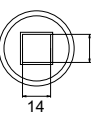

SOJ

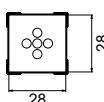
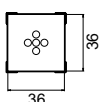
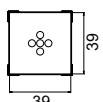
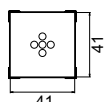
A1214B SOJ 10 × 26 	A1183* SOJ 15 × 8 	A1184B SOJ 18 × 8 
--	---	---

BGA

A1470 BGA 8 × 8 	A1471 BGA 12 × 12 	A1472 BGA 13 × 13 	A1473 BGA 15 × 15 	A1474 BGA 18 × 18 
A1475 BGA 27 × 27 	A1476 BGA 35 × 35 	A1477 BGA 38 × 38 	A1478 BGA 40 × 40 	

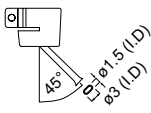
Single

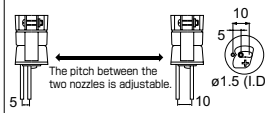
A1124B* Single 2.5 	A1130* Single 4.4 	A1142B* Bent Single 1.5 × 3 	A1190* Dual Single 2.5 × 9.5 	A1325* Dual Single ø1.5 × 5 to 10 Adjustable Pitch 
--	---	--	--	---

SIP

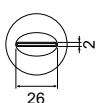
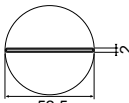
A1191* SIP 25L 	A1192* SIP 50L 
--	--

* The vacuum function does not operate with these nozzles.
 The vacuum function is not available on the FR-801 and the FR-802.

Accessories for SMD-BGA Repair System

Set-up example; Rework fixture, OMNIVISE, FR-803B, FR-830, FG-100



- Combination with HAKKO FR-800 series allows the SMD and BGA rework equipment to set up at low cost.

Features

REWORK FIXTURE 牌 No.C1392B



- Smooth vertical motion
- The handpiece may be easily installed or removed from the clamp.
- Easy to position

OMNIVISE 牌 No.C1390C (Set of 1 piece)



- The height can be adjusted to 72.5 mm, 78.0 mm, 84.5 mm, 91.0 mm and 97.5 mm.
- The jaws are padded to preclude damage to delicate objects.
- Full rotations of 360° are available without interference.

NOZZLE TRAY 牌 No.C1391B



- Holds nozzles in neat rows
- Aids in nozzle installation and removal

Specifications

Model No.	C1392B	C1390C	C1391B
Dimensions	—	ø57 × 88 mm	305 (W) × 64 (H) × 140 (D) mm
Weight	4.6 kg	1.2 kg (1 pc)	0.87 kg

Dimensional drawing for C1392B

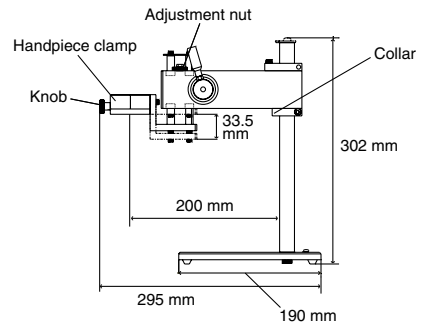

Easy to install and remove the nozzle for C1391B

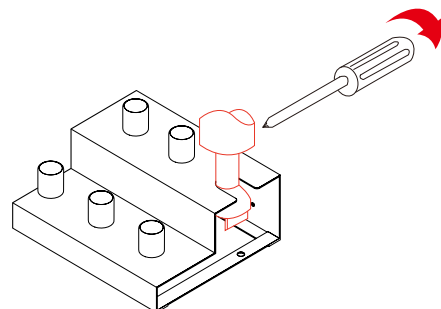

SMD Rework Station

HAKKO 851 ESD SAFE
SMD REWORK STATION

Hot-Air SMD Rework Station Analog

Nozzle included



- Single-nozzle hot air rework system that is perfect for the repair or local heating of small surface-mounted components
- Slim grip is ideal for work in narrow spaces.

Temperature Distribution Chart

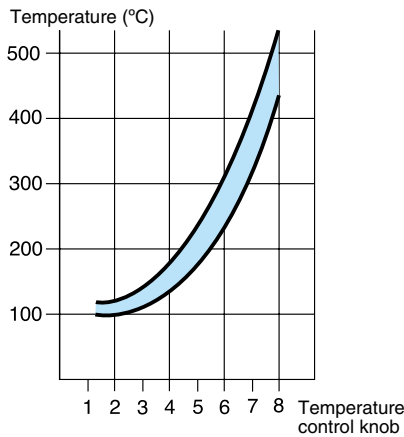

Test criteria

Measured at a point	2 mm from the nozzle
Room temperature	20 °C
Nozzle used	A1066 ø2.0 mm

Replacement Nozzles

Part No.	Name	Specifications
A1065	Nozzle	ø1.5 mm
A1066	Nozzle	ø2.0 mm
A1067	Nozzle	ø3.0 mm
A1147	Nozzle	ø1.0 mm

Packing List

851	Station with handpiece, Handpiece holder, Nozzle holder, Instruction manual
------------	---

Specifications

Model No.	851
Power consumption	85 W
Hot air temperature	100 to 540°C

• Station

Power consumption	5 W
Air flow	6 L/min. (max.)
Dimensions*	167 (W) × 101 (H) × 182 (D) mm
Weight*	1.8 kg

• Handpiece

Power consumption	80 W
Standard nozzle	ø2.0 mm (No. A1066)
Total length**	217 mm
Weight**	180 g

* Without cord and handpiece

** Without cord

HAKKO FA-430 FUME EXTRACTION ESD SAFE

Air-Purifying Smoke Absorber



- Powerful yet quiet suction
- Freestanding flexible ducts facilitate production changeovers
- Three airflow levels are selectable according to working environments.

Packing List

FA-430	Main unit, Power cord, Main filter, Pre-filter (10 pcs), Instruction manual
---------------	---

*Ducts are an optional parts.

Specifications

Model No.	FA-430
Power consumption	120 W
Noise level*	50 dB
Max. suction capacity	With single duct: Max. 4.1 m ³ /min. (145 cFm) With two ducts: Max. 4.7 m ³ /min. (167 cFm)
Filtering efficiency**	99.97% 0.3 μm (LOW or MEDIUM mode) 99.96% 0.3 μm (HIGH mode)
Static pressure	1500 Pa
Duct set (sold separately)***	Duct length: ø55 mm × 1.2 m (ESD safe)
Dimensions	330 (W) × 366 (H) × 343 (D) mm
Weight****	7.5 kg

* Measured at a distance of 1 m from the face of the unit in an anechoic room.

** An initial value of the collection efficiency based on a counting method for airborne dust collected by a single plate of filter (unfolded)

*** Nets in duct sets are not protected against electrostatic discharge.

**** Without cord

Option

Part No.	Name	Specifications
C1571	Duct set	With rectangular type nozzle
C1572	Duct set	With round type nozzle



No.C1571



No.C1572

Features

Quiet operation and powerful suction

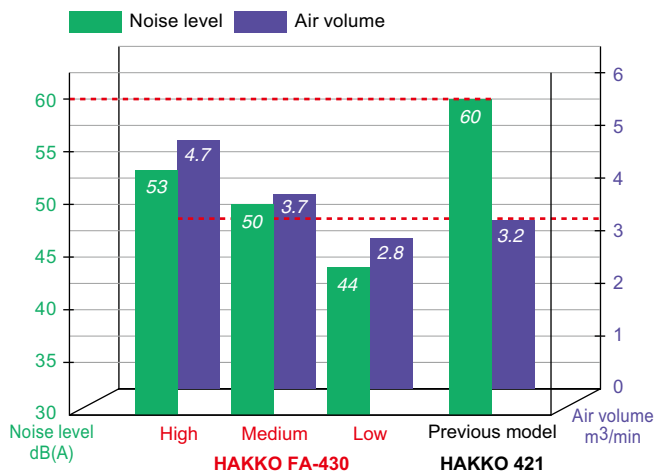

Basic noise level guide

Quiet office = 50 dB
 Ringing telephone, noisy street, or office = 70 dB

Flexible ducts and compact body for perfect placement



Filter replacement notification function

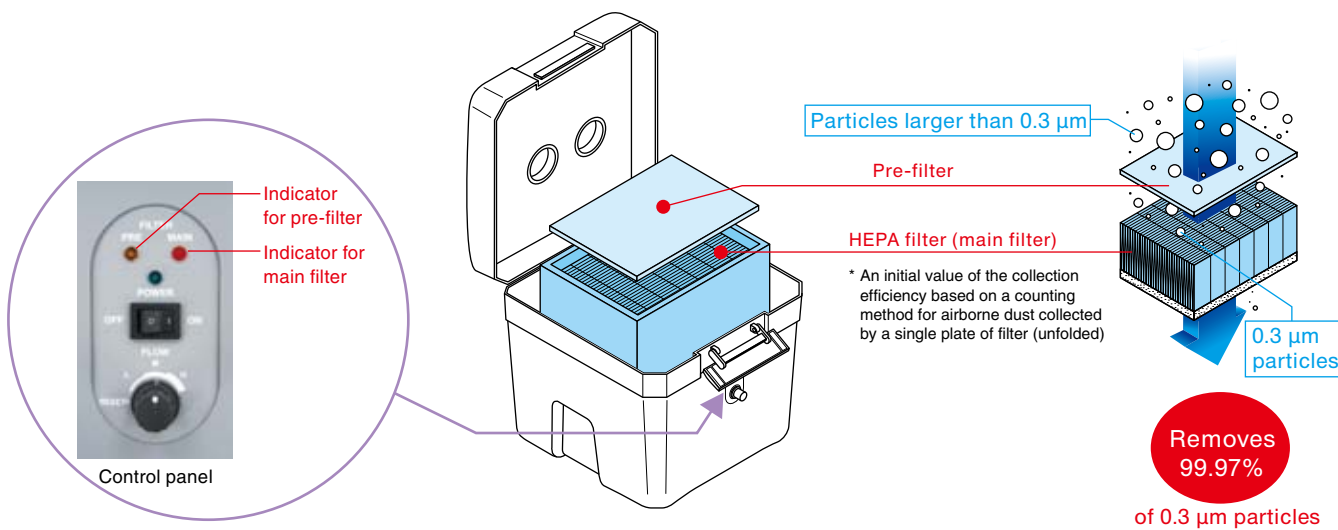

Aerosol particle diameter range

* During LOW and MIDDLE modes

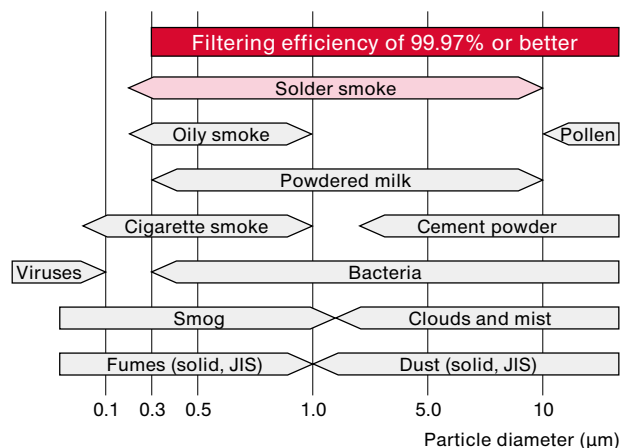

HAKKO 490 SMOKE CLEANER

External Air Compressor Type Smoke Absorber



- External air compressor type soldering smoke absorber
- Three inner filters attached on different levels absorb soldering smoke.
- Up to 2 soldering irons can be connected to one unit.

Compatible Soldering Station for HAKKO 490 and HAKKO 494



FX-888D



HAKKO FX-951



HAKKO FX-950



HAKKO FX-838



HAKKO FM-203



HAKKO FM-206



HAKKO DASH

Specifications

Model No.	490
Noise level	39 dB
Working pressure	392 to 686 kPa (4 to 7 kgf/cm ²)
Air consumption	40 L/min. (490 kPa)
Suction flow	23 L/min. (490 kPa)
Dimensions	ø120 × 200 (H) mm
Weight*	1.5 kg

* Unit only

** Use compressed air; no power supply is necessary.

Packing List

490	Unit, Absorption pipe set, Instruction manual
-----	---

* A second soldering iron can be attached to HAKKO 490 by purchasing an additional absorption pipe set.

HAKKO 494 SMOKE ABSORBER

Smoke Absorbing System



- Soldering smoke absorber for production-line use that enables the exhausting of fumes to an outdoor location
- Equipped with a suppressor to reduce exhaust noise during operation
- Up to 10 soldering irons can be connected to one unit

Example of Connections

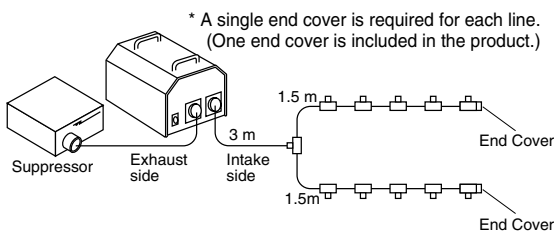

Packing List

494	Unit, Filter case, Filter cap, Pre-filter (5 pcs), Duct (3 m), End cover, Main filter (5 pcs), Inlet socket, Exhaust duct (5 m), Nylon strap, Suppressor, Absorption pipe set, Instruction manual
------------	---

*When ordering HAKKO 494, specify the part number of the absorption pipe set.

Option

Part No.	Name	Specifications
C1540	Absorption pipe set <R>	Any with a handle Φ 16 mm or smaller
B1246	Parallel piping joint	-

Specifications

Model No.	494
Power consumption	50 Hz: 150 W 60 Hz: 200 W
Noise level*	With hose: 55 dB Without hose: 71 dB
Max. suction capacity	50 Hz: 1.56 m ³ /min. 60 Hz: 1.82 m ³ /min.
Static pressure	50 Hz: 2.3 kPa (240 mmAq.) 60 Hz: 3.2 kPa (325 mmAq.)
Dimensions**	322 (W) × 300 (H) × 386 (D) mm
Weight***	18 kg

* Measured at a distance of 1 m from the face of the unit.

** Without handle and cord

*** Unit only

HAKKO FA-400 SMOKE ABSORBER ESD SAFE

Desktop Type Smoke Absorber



- Desktop solder smoke absorber that can be mounted horizontally or vertically
- An optional arm stand makes a third mounting position available.

2 Way Plus Placement

Vertically mounted:



Horizontally mounted:



Using a stand:



Packing List

FA-400	Unit, Filter, Instruction manual
--------	----------------------------------

Specifications

Model No.	FA-400
Power consumption	50 Hz: 15 W (100 V), 18 W (110 V), 19 W (220 V), 22 W (230 V), 24 W (240 V) 60 Hz: 13 W (100 V), 15 W (110 V), 19 W (120 V), 16 W (220 V), 18 W (230 V), 19 W (240 V)
Noise level*	50 Hz: 48 dB 60 Hz: 51 dB
Max. suction capacity**	Vertically: 1.0 m ³ /min. (50 Hz), 1.1 m ³ /min. (60 Hz) Horizontally: 0.4 m ³ /min. (50 Hz), 0.5 m ³ /min. (60 Hz)
Air velocity	Vertically: 1.0 m/s (50 Hz), 1.1 m/s (60 Hz) Horizontally: 2.6 m/s (50 Hz), 2.9 m/s (60 Hz)
Filter size	130 (W) × 130 (H) × 10 (D) mm
Dimensions	166 (W) × 212 (H) × 113 (D) mm
Weight***	0.91 kg

* Measured at a distance of 1 m from the face of the unit

** Measured with a filter present

*** Without cord

Option

Part No.	Name	Specifications
C1568	Arm stand	With knobs

HAKKO FE-510 STATIC ELIMINATOR

Static Eliminator



- Static eliminator enables the selection of the area in which static will be neutralized.
- Locking mechanism maintains the angle of the eliminator unit.
- Error output signal function is useful when incorporating the unit into line applications.

Features

Static elimination area

Wide-angle louver

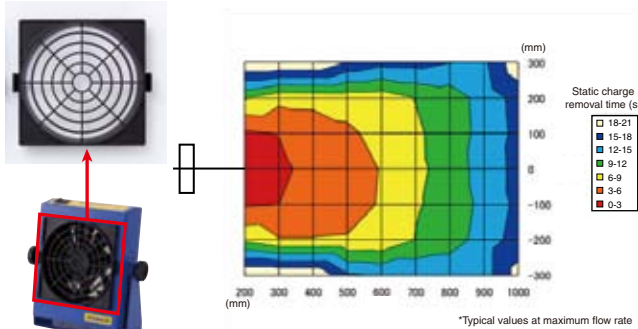

Straight louver

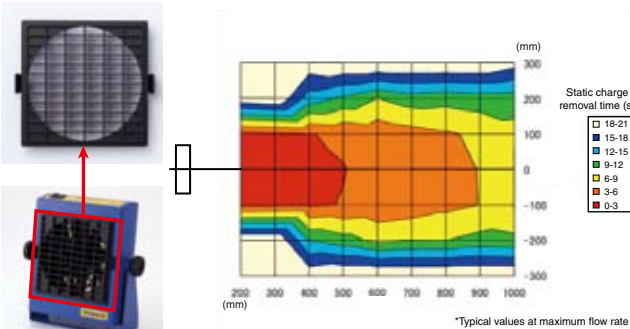

Error output signal

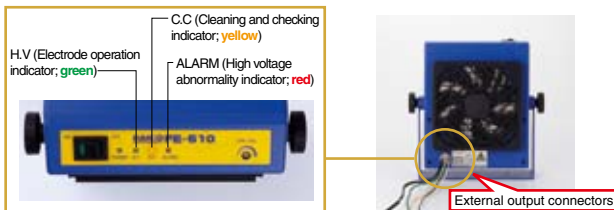

Superb ease of maintenance

The discharge electrode can be replaced simply by turning it gently in the clockwise direction.



Packing List

FE-510	Unit, Straight louver, Cleaning brush, Filter, AC adapter, Output signal connection lead (1 set), Instruction manual
--------	--

Specifications

Model No.	FE-510
AC adapter output/Capacity	DC 24 V 10 VA
Discharge method	High frequency AC method
High voltage output	Approx. AC 2,000 V
Ion balance*	±10 V or less
Static elimination time*	Straight louver: Approx. 1.5 sec. Wide-angle louver: Approx. 2.5 sec.
High voltage abnormality output (ALARM)	MOS FET relay non-voltage contact output Max. current: 100 mA Applied voltage: DC 30 V or less
Cleaning check output (C.C)	MOS FET relay non-voltage contact output Max. current: 100 mA Applied voltage: DC 30 V or less
Air flow	1.5 to 3.0 m ³ /min.
Air flow out angle	Vertically 360° variable (every 10°)
Quantity of produced ozone**	0.04 ppm or less
Operating environment	Ambient temperature: 0 to 40°C Ambient humidity: 15 to 65% (without condensation)
Material for discharge needles	Tungsten
Dimensions	150 (W) × 182 (H) × 50 (D) mm (without stand)
Weight***	0.79 kg

AC adapter

AC adapter output/Capacity	DC 24 V 1 A
Dimensions	34 (W) × 72 (H) × 51 (D) mm
Weight	100 g

* Typical value measured (before shipment) at a distance of 300 mm from the center of the fan outlet with the maximum flow rate

** Measured at a point 150 mm away from the center of the fan outlet

*** Including stand

HAKKO 442B

WRIST STRAP

Wrist Strap



- This antistatic wrist strap prevents the human body from becoming charged with static electricity.
- The stretchable band is easy to adjust.
- A conductive thread is used for the band lining.

Cord helper

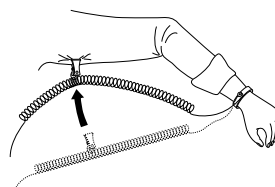

1. Insert the grounding wire into the ring of the cord helper.
2. Clip the cord helper to clothing as shown here.

Packing List

442B	Wrist band, Grounding wire, Cord helper, Instruction manual
------	---

Specifications

Part No.	442B-01	442B-02
Color	Blue	
Grounding wire	1.5 m	2.5 m

HAKKO 496

WRIST STRAP

Wrist Strap

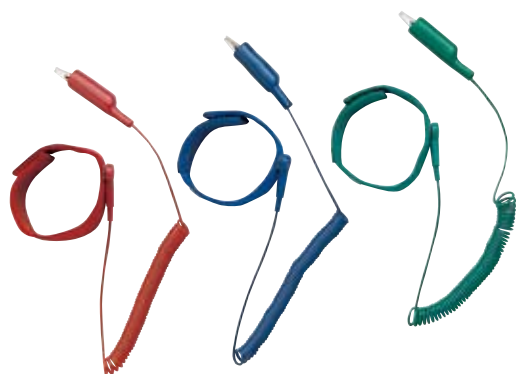

- Hook and loop fastener is easy to remove.

Packing List

496	Wrist band, Grounding wire, Instruction manual
-----	--

Specifications

Part No.	496B	496R	496G
Color	Blue	Red	Green
Grounding wire	2 m		

HAKO FG-450

STATIC LEVEL METER

Static Level Meter



- Portable static level meter for the measurement of electric potential of films and plastic objects
- Useful when checking electric potential measurements in production lines.
- Also suitable for performing operation test of static eliminators.

Features

Rotating sensor head



Selectable two modes in measurement

- Measuring static electricity (Resolution: 10V)



The red light image is projected to a point about 30 mm from the meter.



- Measuring ion balance (Resolution: 1V)



Packing List

FG-450	Unit (with carrying case), Grounding wire, Strap, 006P 9 V Manganese dry battery (for trial), Ion balance plate (with screw), Instruction manual
---------------	--

Specifications

Model No.	FG-450
Power supply	006P 9 V dry battery
Measurable potential range	Normal mode: 0.00 to ± 19.99 kV (resolution: 0.01 kV) Ion balance mode: 0.000 to ± 1.999 kV (resolution: 0.001 kV)
Signal detection method	Oscillating chopper method
Display refresh frequency	0.5 seconds
Measurement precision	$\pm 10\%$ of reading ± 2 digits
Continuous operating limit	Approx. 10 hours (with an alkaline battery)
Measurement distance	30 mm (between object being measured and sensor)
Measurement distance adjustment	Red LED beam focusing method
Sensor head rotation angle	180° (in increments of 45°)
Display	LCD display with built-in backlight
Polarity display	Positive polarity/negative polarity display
Mode switching	Ion balance/static electricity measurement modes
Battery check	Remaining charge displayed in display panel
Operating environment	0 to 40°C, 20 to 70%RH (without condensation)
Dimensions	68 (W) \times 138 (H) \times 22 (D) mm
Weight*	160 g

* Including battery

Option

Part No.	Name	Specifications
B3586	Body changing level measurement plate	-

HAKKO FG-100

THERMOMETER

Soldering Iron Thermometer



- Tip thermometer that provides reliable temperature control of soldering iron tips
- Compact design minimizes your workspace and enables you to easily carry it around.
- Incorporating an extremely fine sensor that has high temperature reactivity.

HAKKO FG-101

SOLDERING TESTER

Soldering Iron Tester



- Tip temperature, leak voltage, and tip-to-ground resistance can be easily measured with high accuracy.
- Soldering iron tester useful for daily maintenance of station-type soldering irons

What is leak voltage and tip-to-ground resistance?

Leak voltage

Leak current is the current that leaks from the tip to a board or device. Leak voltage is a specific measurement of the level of this current. The leakage can adversely affect delicate devices, so it is necessary to check leak voltage on a daily basis.



Tip-to-ground resistance

Most leak current flows from the tip via the ground wire to the outlet ground terminal, and is prevented from affecting the device. Because of this, tip-to-ground resistance is another important issue that must be checked daily.

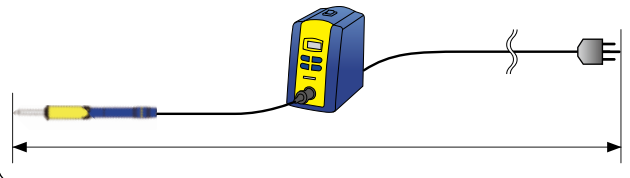

Common features of FG-100 and FG-101

Dimensional measurement



*Design image only

MAX HOLD function

When the “MAX HOLD” button is pressed, “MAX HOLD” is displayed and the highest tip temperature is held on the display.



Option / Replacements

Part No.	Name	Specifications
A1310	Temperature probe	For solder bath and pot
C1541	Temperature probe	For hot air
A1556	Sensor A	-
A1557	Sensor B	-

Packing List

FG-100	Unit, 006P 9 V Manganese dry battery (for trial), Instruction manual, Sensor (10 pcs)
FG-101	Unit, Fuse, Conduction wire, Sensor (10 pcs), Multi-adapter, European adapter, Ground clip, Power cord, Instruction manual

Specifications

Model No.	FG-100
Power supply	006P 9 V dry battery
Temperature resolution	1°C
Temperature measurement range	0 to 700°C
Temperature precision	±3°C (300 to 600°C) ±5°C (other than above)
Temperature sensor	K (CA) type thermocouple
Display*	Besides measured temperatures, display indications include the following: <div style="display: flex; align-items: center; justify-content: center;"> <div style="margin-right: 10px;">Battery low alarm</div>  <div style="margin-left: 10px;">Burnout alarm MAX HOLD</div> </div> <p>“MAX HOLD” is displayed in the lower right of the LCD.</p>
Operating environment	0 to 40°C, 20 to 90%RH (without condensation)
Environmental conditions	Applicable rated pollution degree 2 (according to IEC/UL 61010-1)
Dimensions**	68 (W) × 140 (H) × 38 (D) mm
Weight***	115 g

* When the battery low alarm appears, be sure to replace the battery. Failure to do so will result in incorrect temperature measurements.

** Excluding protrusions

*** Excluding battery

Model No.	FG-101
Power consumption	2.6 W (100 V), 2.9 W (110 V), 2.6 W (120 V), 2.7 W (220 V), 2.8 W (230 V), 3.0 W (240 V)
Temperature resolution	1°C
Temperature measurement range	0 to 700°C
Temperature precision	±3°C (300 to 600°C) ±5°C (other than above)
Temperature sensor*	K (CA) type thermocouple
Voltage resolution	0.1 mV
Voltage measurement range	0 to 40 mV (CA)
Voltage precision	± (5% of reading + 1 digit)
Resistance resolution	0.1Ω
Resistance measurement range	0 to 40Ω
Resistance precision	± (5% of reading + 1 digit)
Display**	LCD: 3 1/2 digits Burnout: -1 MAX HOLD: “MAX HOLD” is displayed in the lower right of the LCD.
Operating environment	0 to 40°C, 20 to 90%RH (without condensation)
Environmental conditions	Applicable rated pollution degree 2 (according to IEC/UL 61010-1)
Dimensions	200 (W) × 50 (H) × 120 (D) mm
Weight***	1 kg

* The temperature sensor (No.191-212 or No.191-212C) can only be used to measure temperatures below 500°C. To measure higher temperatures, use an applicable temperature probe.

** When a sensor is not attached or it burns out, the Burnout (-1) alarm symbol is displayed. The same symbol is also displayed when a temperature outside the measurement range is detected.

*** With power cord

HAKKO 498 SYSTEM TESTER

Wrist Strap Tester



- Easy-to-use, quick-response tester for wrist straps

Features

Can be used anywhere to quickly and easily check a variety of grounding systems.



Packing List

498	Unit, 006P 9 V Manganese dry battery (for trial), Grounding wire, Instruction manual
-----	--

Specifications

Model No.	498
Power supply	006P 9 V dry battery
Indication: LOW	$R < 800 \text{ k}\Omega$
Indication: GOOD	$800 \text{ k}\Omega \leq R \leq 9 \text{ M}\Omega$
Indication: HIGH	$R > 9 \text{ M}\Omega$
Battery life	Approx. 50,000 times
Grounding wire	2.5 m
Operating environment	0 to 40°C, 20 to 90%RH (without condensation)
Dimensions	80 (W) × 40 (H) × 117 (D) mm
Weight*	150 g

* Including battery

HAKKO MELTER

Glue Gun



- Glue gun with temperature control function is applicable also to the adhesion of electronic components.
- Useful when fixing up sealing of carton boxes, dressing cases, and packages
- Only used with a stick-type adhesive that is easy to replenish (ø11.5 mm)

Applications

When using polyamide adhesives

- Reinforce and insulate soldered parts.
- Fasten capacitors, resistors, etc.
- Fasten jumper wires.
- Perform insulation potting for terminals.
- Fasten the ends of coils.
- Fasten deflecting yokes and variable coils.

When using EVA adhesives

- Glue paper products (cardboard boxes, gift boxes, etc.).
- Fasten wood products.
- Fasten plastics and metals.
- Fasten textiles and shock absorbent packing.
- Reseal products during packaging.

Packing List

804	Unit, #13 Spanner, #14 Spanner, Instruction manual
------------	--

Specifications

Model No.	804
Power consumption	100 W
Melting temperature	100 to 200°C (variable)
Standard nozzle	ø2.0 mm (No. A1083)
Discharge capacity	900 g/h
Dimensions	207 (L) × 173 (H) × 45 (D) mm
Weight*	350 g

* Without cord

Adhesive Used

This model has been designed for use with stick adhesives (those hardened into the shape of a stick) only. Be sure to use adhesives recommended by HAKKO.
(No. 810: UL94V-O recognized)

Part No.	810	811	812
Name	Polyamide	EVA	
Packing	1 kg		14 pcs
Color	Yellowish brown	Milky white	
Size	ø11.5 × 220 mm		
Viscosity	2,300 cps. (2,300 mPa·s)	5,800 cps. (5,800 mPa·s)	
Open time*	10 seconds	40 seconds	
Temperature at which adhesive is heat resistant	100°C	55°C	
Suitability	P.W.B.	○	—
	Wood	○	○
	Paper	○	○
	Metal	○	○
	Plastic	○	○
Packing	In aluminum foil bag	In polyethylene bag	In blister pack

Adhesives marked with ○ are more suited for that material than adhesives marked with ○.

* Application period

HAKKO HEATING GUN

Heating Gun



No. 880B 880 W

Ideal for heat shrinking of shrink films with low heat resistance. Optional nozzle makes local heating work possible.



No. 881 1000 W

General-purpose type: The range of applications can be expanded by using a variety of optional nozzles.



No. 882 1000 W

Temperature is freely adjustable within the range of room temperature to 450°C.

Applications

Drying of paints	Perfect for drying paints locally
Shrink film	Heat shrinking of films
Shrink tubing	Heat shrinking of electric wire covers
Putty	Repair work using putty including repairs of automotive bumpers
Interior decor	Vinyl cloth, floor materials, flooring work
Plastic moldings / Rubber products	Bending, fitting, and assembly of plastic products (heat plasticity)
PVC pipe	Bending work
Stone	Drying of stone after polishing, drying of surface-lustering agent, drying of paint finish, drying before rubber lining (printing of names, etc.)
Removal of labels	—
Thermosetting resin	Expediting setting
Defrosting	Heating water pipes and machinery frozen in winter

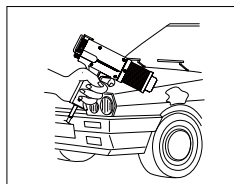

Spot drying of coating material and coating putty

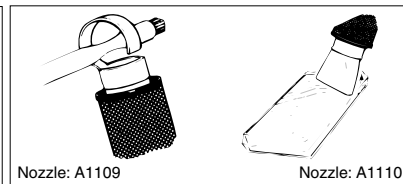

Heating of shrink tubing and shrink film

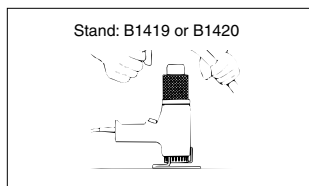

Bending and welding of PVC pipes

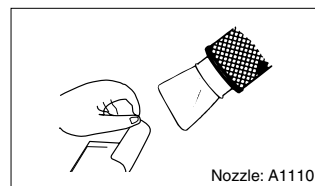

Removing stickers, labels, and gummed tape

Packing List

880B, 881, 882	Unit, Instruction manual
-----------------------	--------------------------

Option

Part No.	Name	Specifications
A1109	Nozzle	Hook type For 880B, 881, 882
A1110	Nozzle	Spatula type, 62 mm For 880B, 881, 882
A1111	Nozzle holder	For 881, 882, 880B
A1112*	Nozzle	For 881, 882
A1113*	Nozzle	Single, ø5 mm For 880B
A1114*	Nozzle	Spatula type, 20 mm For 881, 882, 880B
A1115	Roller	For 881, 882, 880B
B1419	Stand <L>	For 880B, 881
B1420	Stand <L>	For 882

* Must be inserted into part number A1111.

Specifications

Model No.	880B	881	882
Power consumption	880 W	1,000 W	1,000 W
Maximum temperature*	400°C	450°C	Room temperature to 450°C (variable)
Air velocity	330 m/min.	360 m/min.	360 m/min.
Air flow	0.18 m ³ /min.	0.2 m ³ /min.	0.2 m ³ /min.
Dimensions	245 (W) × 185 (H) × 70 (D) mm	245 (W) × 185 (H) × 70 (D) mm	285 (W) × 185 (H) × 70 (D) mm
Weight**	0.62 kg	0.62 kg	0.7 kg

* Approximate value measured at a point 10 mm from the hot air outlet

** Without cord



HEAD OFFICE

4-5, SHIOKUSA 2-CHOME, NANIWA-KU, OSAKA, 556-0024 JAPAN
TEL: +81-6-6561-3225 FAX: +81-6-6561-8466
<http://www.hakko.com> E-mail: sales@hakko.com

OVERSEAS AFFILIATES

U.S.A.

AMERICAN HAKKO PRODUCTS, INC.

28920 N. AVE. WILLIAMS VALENCIA, CA 91355, U.S.A.
TEL: (661) 294-0090 FAX: (661) 294-0096
Toll Free (800)88-HAKKO
4 2 5 5 6
<http://www.hakkousa.com>

HONG KONG

HAKKO DEVELOPMENT CO., LTD.

ROOM 1504, EASTERN HARBOUR CENTRE,
28 HOI CHAK STREET, QUARRY BAY, HONG KONG.
TEL: 2811-5588 FAX: 2590-0217
<http://www.hakko.com.hk> E-mail: info@hakko.com.hk

SINGAPORE

HAKKO PRODUCTS PTE., LTD.

1, GENTING LINK #02-04,
PERFECT INDUSTRIAL BUILDING, SINGAPORE 349518
TEL: 6748-2277 FAX: 6744-0033
<http://www.hakko.com.sg> E-mail: sales@hakko.com.sg

Please access to the following address for the other Sales affiliates.

<http://www.hakko.com>